

AI-WIRELESS ROBOTIC POOL CLEANER USER MANUAL

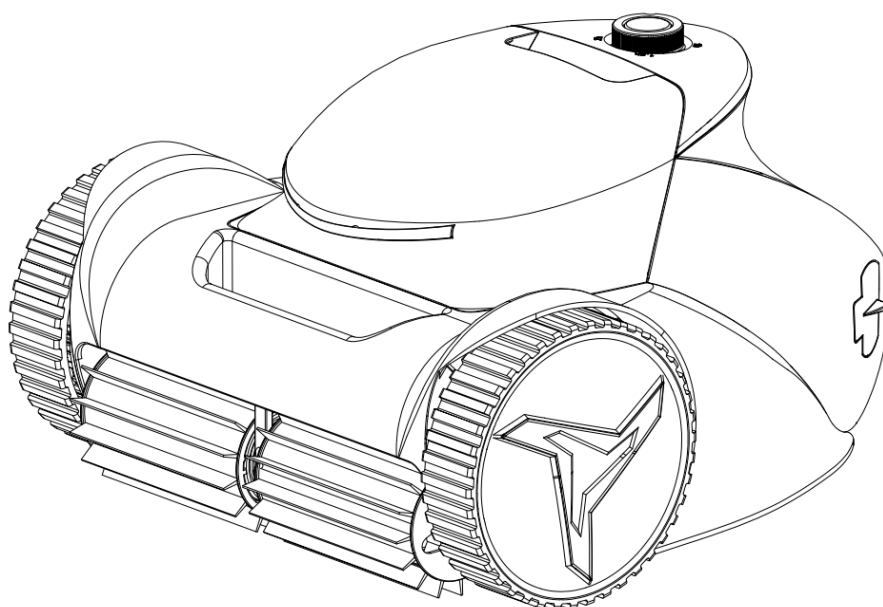

XA20/29/44/58/70

**THANK YOU FOR PURCHASING XA20/29/44/58/70 AI-WIRELESS ROBOTIC
POOL CLEANER**

*Please read the manual carefully before installing or using it and keeping it for
subsequent use.*

★★ TIPS★★

ALL pool cleaners are Designed to Keep a Clean Pool Clean, NOT FIX A FILTHY SWAMP.

How to achieve the most efficient cleaning

Place the robot at the edge of the pool for quick coverage of the entire pool floor area.

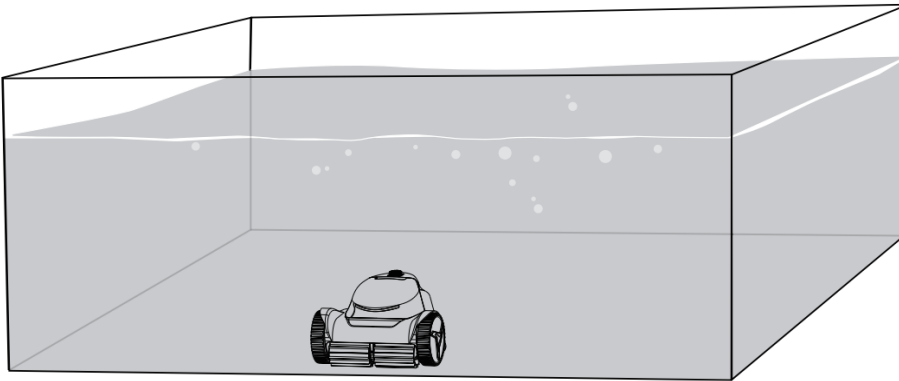

How to drain water from the robot

Place the robot on the edge of the pool for a while and let the water drain out.

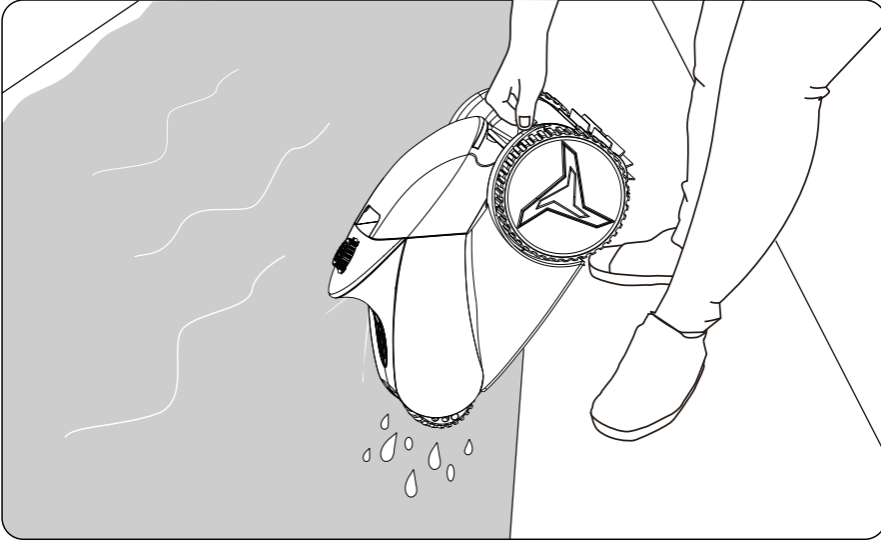

How to open the filter box

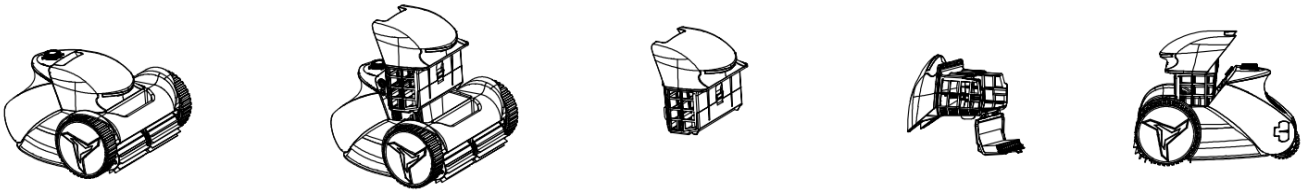

! *Do not charge the robot outdoors.*

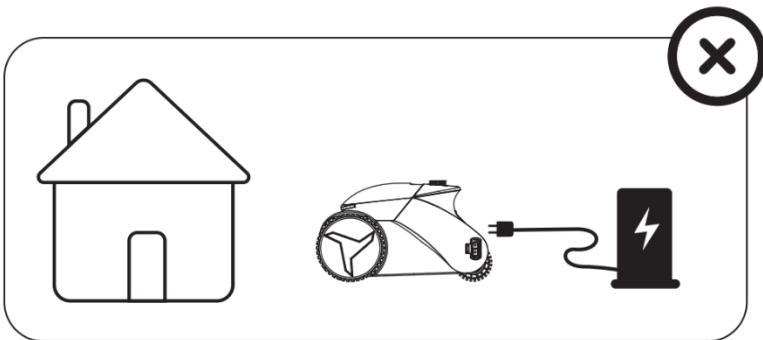

! Do not long-term expose the robot to the sun.

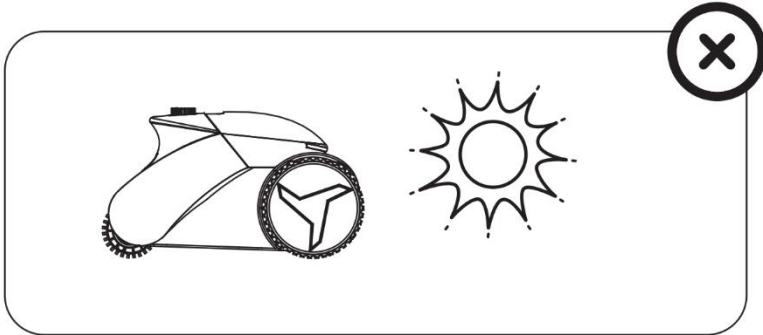

WARNINGS

This page contains information that will help you operate the robot safely, prevent hazards and damage to the robot or other property.

GENERAL WARNINGS

- Read the instructions before operating the robot.*
- The robot is designed for pool cleaning; do not use it for other purposes.*
- Keep the robot out of reach of children or persons with reduced physical, sensory or mental capabilities without supervision or instruction.*
- The robot must be installed, operated and maintained as specified in this manual.*
- The robot is to be installed in accordance with manufacturer's guidelines and in compliance with the relevant requirements of the local or national standards for installation. The manufacturer is not responsible for any outcome related to the failure to comply with installation, usage or maintenance guidelines.*
- Incorrect installation or use of the robot may cause serious damage to property or injuries to people.*
- Do not enter pool while the robot is in water.*

WARNINGS ON USE

- Only use the detachable supply unit provided with the robot to recharge the battery. It is suggested to operate the power supply at least 3.5 meters from edge of pool.*
- Disconnect the robot from the power supply and power switch is OFF before performing any maintenance on the robot.*
- Do not try to repair the robot yourself or open motor box in case of malfunction, please contact your dealer.*
- If there is any malfunction or release of odor from the robot when charging, disconnect*

it from the power supply immediately and contact your dealer.

- Use only original replacement parts supplied by the manufacturer for service and repair.

GENERAL OPERATION CONDITIONS

Water depth range(m)	Water temperature(°C)	PH	NaCl(PPM)	Chlorine(PPM)
1-2.5	4-35	7,0-7,8	5000 MAX	4 MAX

Note: water temperature below 15°C, the endurance time may be affected.

- The robot is recommended for private pools.
- The robot will automatically stop running if the water depth is less than 40 centimeters for the purpose of motor protection.
- Do not use the robot during shock chlorination.
- Do not use the robot in thunderstorm or stormy weather.
- Do not expose the robot to direct rainfall or sunlight for an extended period.

CAUTIONS

- Hold the robot by the pool edge to let the water drain out before lifting from the pool, do it slowly so as to prevent back injury.
- Clean the filter basket after each cleaning cycle.
- Do not lift the robot out of water by brush roller.

REMINDER

- When the robot battery is lower than 30%, it will clean the floor only.
- In the Floor/Wall/Waterline mode, if the robot fails to climb the wall 5 times in a row, it will automatically switch to floor mode.
- Storing your robot:

- a. Ensure the robot is fully dry before storage. This prevents degradation or damage to the motors or internal structure.
- b. The filter basket should be cleaned thoroughly after usage and do not leave dirt or debris to dry in filter basket.
- c. The charger cable is stored neatly without twists whilst in long-term storage.
- Optimum storage temperature between $-10-45^{\circ}\text{C}$ and storage humidity between 30%-70%/RH.
- In the floor mode, the robot can not work in $>30^{\circ}$ slope.

Table of Contents

SECTION 1. PRODUCT OVERVIEWS	1
1.1 Packaging content.....	1
1.2 Technical specification.....	2
1.3 Preparation.....	3
SECTION 2. OPERATION.....	5
2.1 Overview of Control Panel.....	6
2.2 Operation on the display of the unit.....	9
2.3 Cleaning the filter basket.....	11
2.4 Charging the robot.....	12
SECTION 3. MAINTENANCE.....	14
3.1 Filter basket.....	14
3.2 Impeller maintenance.....	15
3.3 Replace the worn brushes.....	<i>Chyba! Záložka není definována.</i>
SECTION 4. TROUBLESHOOTING.....	18

SECTION 1. PRODUCT OVERVIEWS

1.1 Packaging content

The following items are included in the packaging of robot. Please contact your dealer if any damage or loss.

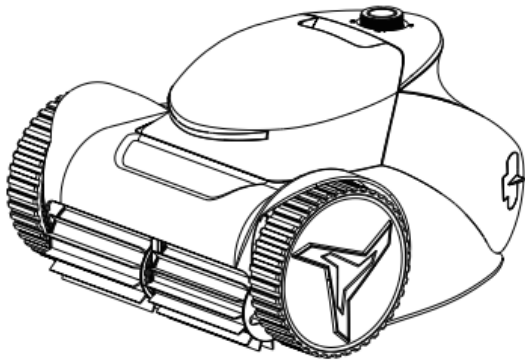

①

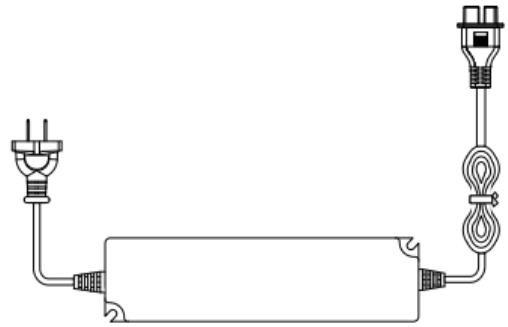

②

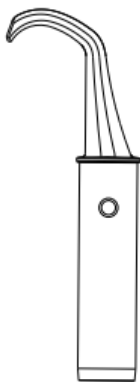

③

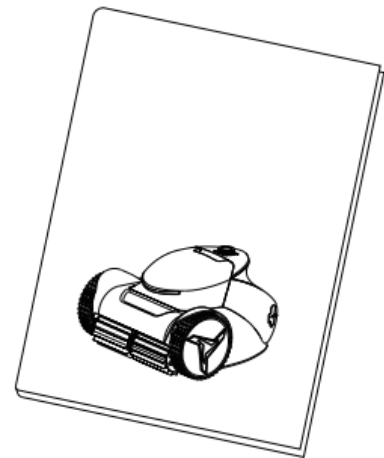

④

① The robot ② Charger ③ Hook ④ User manual

Note:

1. The power must be ON when the robot is in use or charging. When the robot

is not in use, please turn the power OFF to protect the battery.

1.2 Technical specification

Model	XA70	XA58	XA44	XA29	XA20
Endurance condition reference*: Floor mode					
Endurance time	7h	5.8h	4.4h	2.9h	2.0h
Charging time	6h	5h	3.5h	3.5h	3.5h
Battery	7.5Ah		5.0Ah		
Pool size	6×10m				
Optimum pool temperature	4~35°C				
Cleaning mode	Floor only; Floor/Wall/Waterline				
Cleaning time	1h/1.5h/2h/Max				
Filter capacity	3.2L				
Filtration accuracy	120µm				
Pump flow rate	15-20(m ³ /h)				
Running power	20-100W				
Moving speed	12m/min				
Number of motors	3				
Charger input	100-240VAC ~ 50/60Hz				

Running voltage/current	25.5V/1A				
Robot NW	8.5kg	7.5kg	7kg	6.5kg	6.5kg
Robot dimension (L*W*H)	440*400*238mm				
Robot packaging dimension (L*W*H)	504*450*300mm				

Cleaning time reference:

Clean once in Floor mode: 30 minutes (4*8m swimming pool as an example).

Note: The manufacturer reserves the right to modify these specifications without notice.

1.3 Preparation

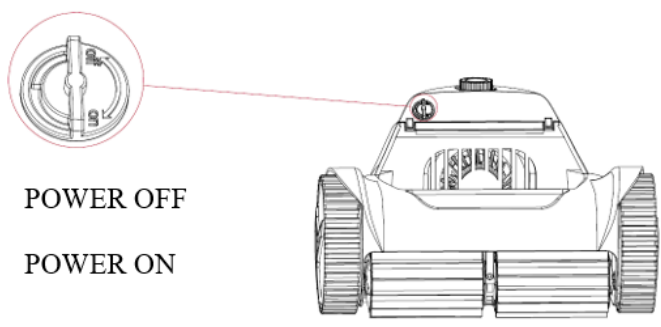
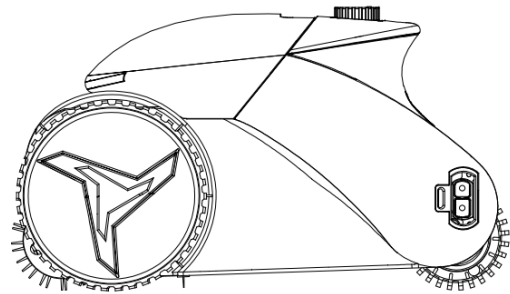
<p>① Power switch.</p>  <p>POWER OFF POWER ON</p>	<p>② Remove the plug cover. When fully charged, re-cover the plug. Do not immerse the robot in water without putting the charging port cover back on the robot.</p> 
--	--

③ Connect to the power supply(100-240V) using the attached charger.

Battery level is shown on the battery bar, when all 3 bar lights  are on, it is fully charged. (When

charging, press the button to show the battery status)

Fully charge the robot before the first use.

*Suggested Charging Temperature: 6-35°C.

(If the temperature is higher than 50°C, the robot will not be charged.)

④ Install the configured hook on the rod (Rod is exclusive).

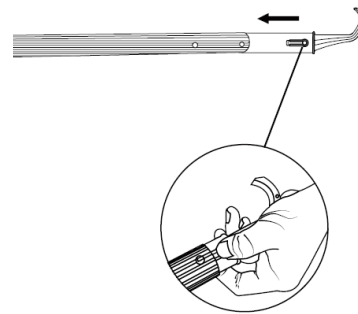

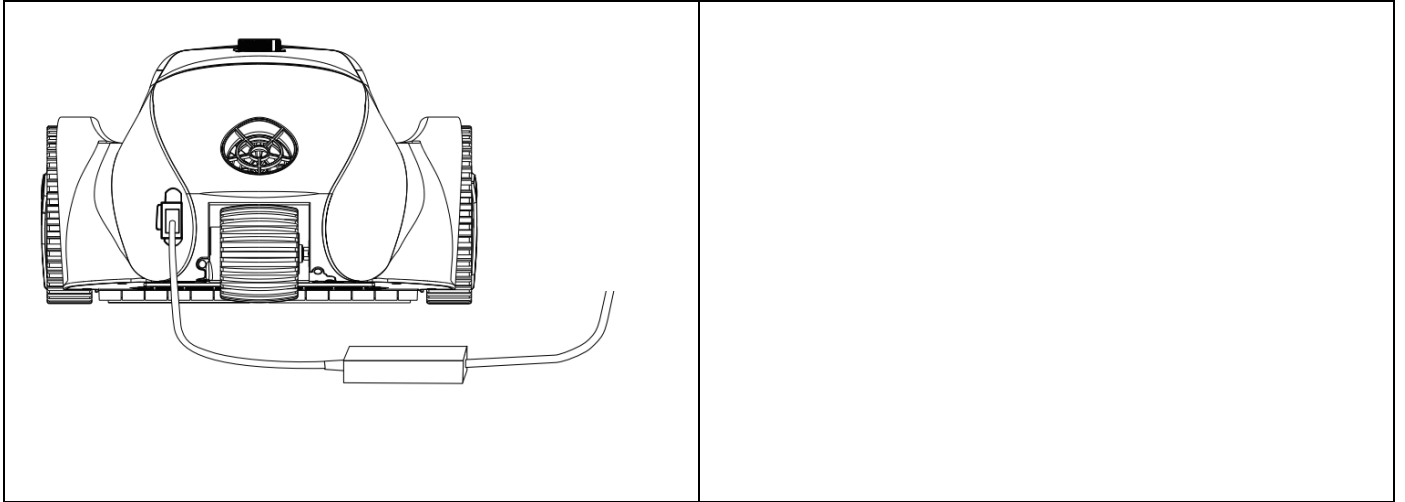

SECTION 2. OPERATION

⚠ CAUTION

To prevent potential damage to the robot or people, be sure to follow these guidelines:

- After cleaning, store the robot in a cool, dry place out of direct sunlight.*
- Carefully remove the robot from the pool and drain the water before lifting.*

IMPORTANT

- Once the robot is set up, drop into the water within 3 minutes or the robot will enter sleep mode.*

- Clean the filter basket after the cleaning cycle. Avoid cleaning the surface of the filter mesh directly with your hands.
- The robot has a safety feature that automatically stop running if the water depth is less than 40 centimeters. When placing the robot into the pool water, ensure it is fully submerged, then turn the robot in all directions to release any air trapped in the robot before it enters the water.

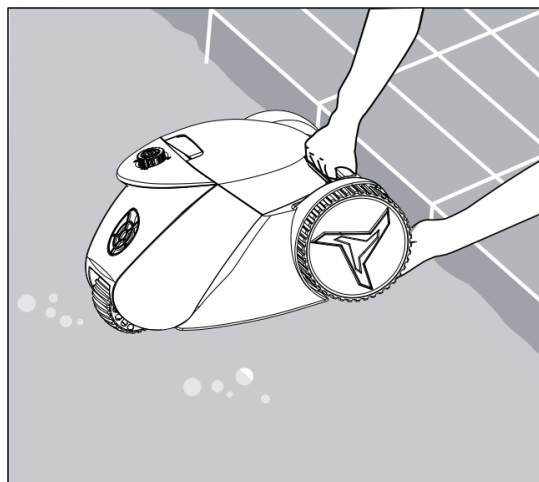

2.1 Overview of Control Panel

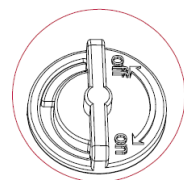



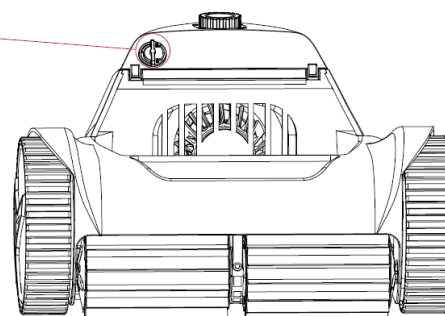

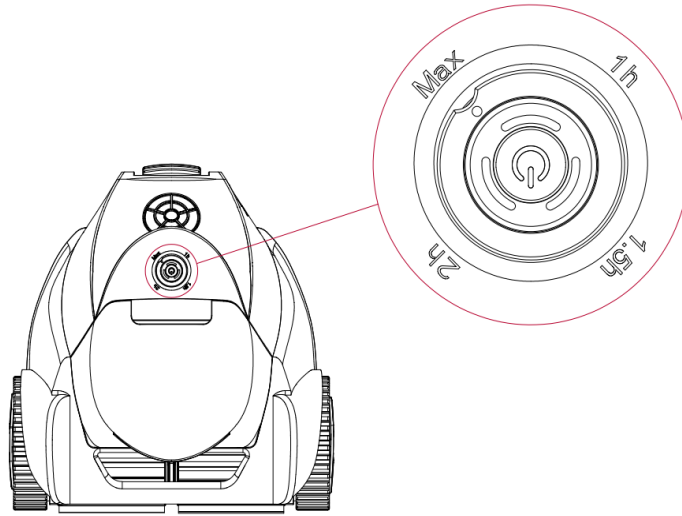

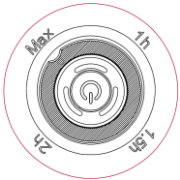

POWER OFF
POWER ON







The following description shows that the robot is in the ON operable state:

Button	Icon	Display Status	Description
Power switch		Lights (Green/Blue) flashing	Setup status
		Lights OFF	Sleep status/Power OFF status
		Lights ON	Running status/Inspection status under water
Cleaning time		Arrow pointing 1h	Cleaning time: 1 hour
		Arrow pointing 1.5h	Cleaning time: 1.5 hour
		Arrow pointing 2h	Cleaning time: 2.0 hour
		Arrow pointing Max	Cleaning until low battery

Cleaning mode		Green lights being on	Floor cleaning mode
		Blue lights being on	Overall cleaning mode (Floor, wall, waterline)
Battery light (Non-charging status)		1 light being on	Battery level: 30-40%
		2 lights being on	Battery level: 40-70%
		3 lights being on	Battery level: 70-100%
Low battery		1 light flashes	Battery level below 30%
Battery light (Charging status)		3 lights flash in cycle	Charging
		3 green lights being on	Battery level: 100%
Error		1 flashing red light (Left)	Left drive failure
		1 flashing red light (Right)	Right drive failure
		1 flashing red light (Bottom)	Water pump failure

		2 flashing red lights (Left & Bottom)	Gyroscope failure
		2 flashing red lights (Left & Right)	Water sensor failure

2.2 Operation on the display of the unit

1. Switch the power to ON, the buzzer will beep and the light will flash (Default cleaning mode is Floor mode for the first time - green light), and you can start operating the setting.

Press the button to choose the cleaning mode, rotate the button to select the cleaning time, please align the arrow on the knob with the time you want to choose as shown below.

Once the setting is completed, put the robot into the pool, it will automatically start cleaning when it touches the floor.

If there is no operation when the light flashes within 3 minutes, the robot will stop running and enter sleep mode. Short press of the button to awake the robot in sleep mode.

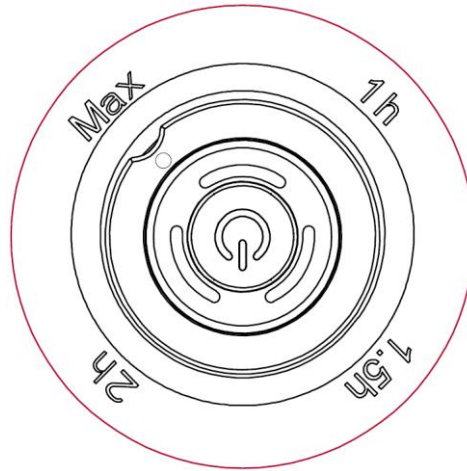

Note: Please make sure that the arrow on the knob is aligned with the set cleaning time. If the arrow is not in the right position at the setting time, the cleaning time will be subjected to the left side of the arrow.

2. If the battery is lower than 15% during the cleaning cycle, one bar light will keep flashing, then the robot will self-park at the pool side and enter sleep mode after 3 minutes.

2.3 Cleaning the filter basket

After a cleaning cycle, the robot will self-park at the pool side. Use the hook to catch the handle and lift the robot out of the water, drain the water from the robot and clean the filter basket as shown below:

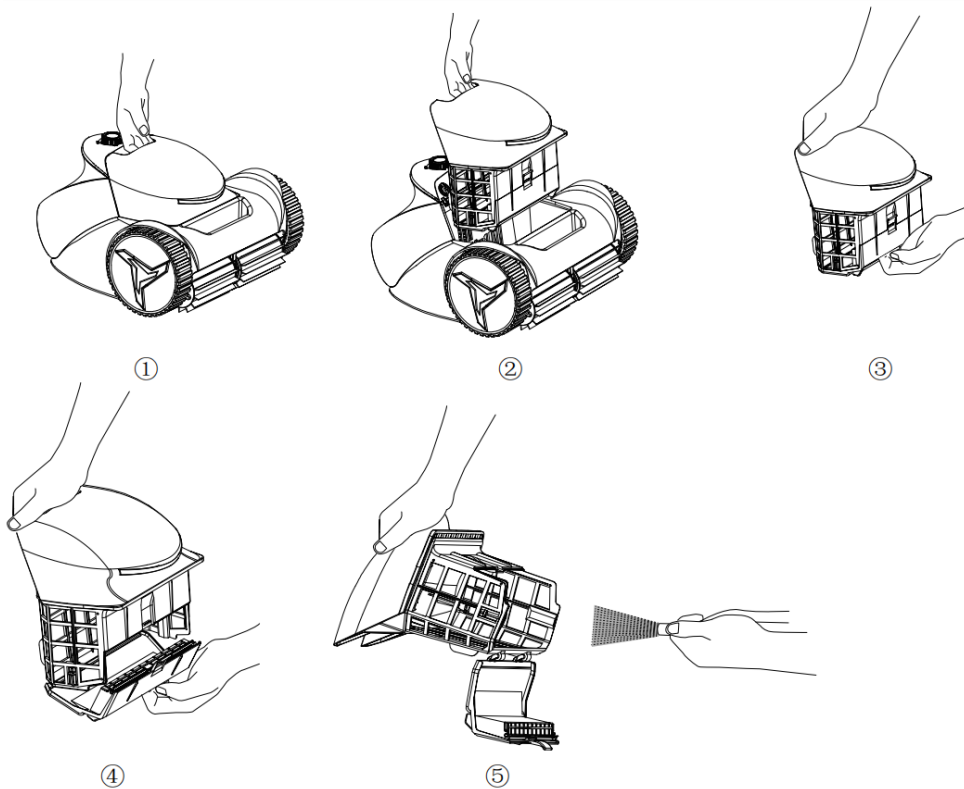

Note:

To prevent injury, wear rubber gloves when cleaning the filter basket.

2.4 Charging the robot

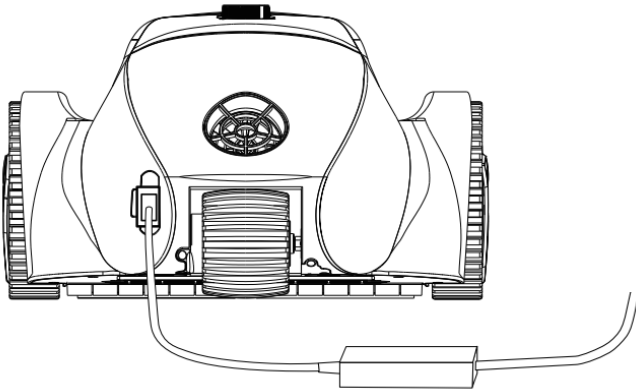

1. Take the cover off the charging port. The charging port cover will remain tethered to the robot's body – do not lose the charging port cover.
2. Ensure the charging port and the charger are dry before charging.
3. Plug the charger into the robot first and then into a 100-240V power supply. When the battery light on the robot is flashing in a circle, the robot is charging.
4. When the battery light on the robot has 3 green bar lights on, the robot is fully charged.
5. Once the robot is fully charged, turn the power off at the wall, then unplug the charger from the robot and the power supply. Store the charger in a safe place. To protect the battery, do not leave the charger plugged into the robot after charging has completed.
6. Insert back the cover into the robot's charging port.
7. If the robot will not be used for an extended period of time, it should be fully charged at least every three months to protect the battery.

Note: Only use the original charger to charge the robot. Using any other charger will void the warranty.

SECTION 3. MAINTENANCE

⚠ WARNING

- 1. To avoid electric shock and other hazards which could result in serious injury, disconnect the adapter from the power source before performing any cleaning and maintenance.*
- 2. Before performing any maintenance, turn the power switch OFF to prevent injury from impeller rotation.*

3.1 Filter basket

- 1. Clean the filter thoroughly and regularly for better cleaning and climbing performance. Otherwise, the cleaning and climbing performance may be affected when the filter is full or clogged.*
- 2. Clean the clogged filter annually with a mild acidic detergent. Wear appropriate protective clothing while cleaning.*

3.2 Impeller maintenance

Visually check whether the impeller or impeller shaft is entangled with hair or other debris. If the robot has a reduced suction or climbing performance, clean the debris trapped in the impeller.

**The power switch MUST be OFF before any maintenance on the impeller.*

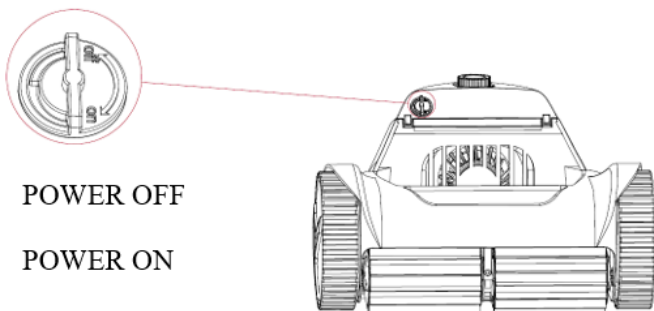

Follow the below steps:

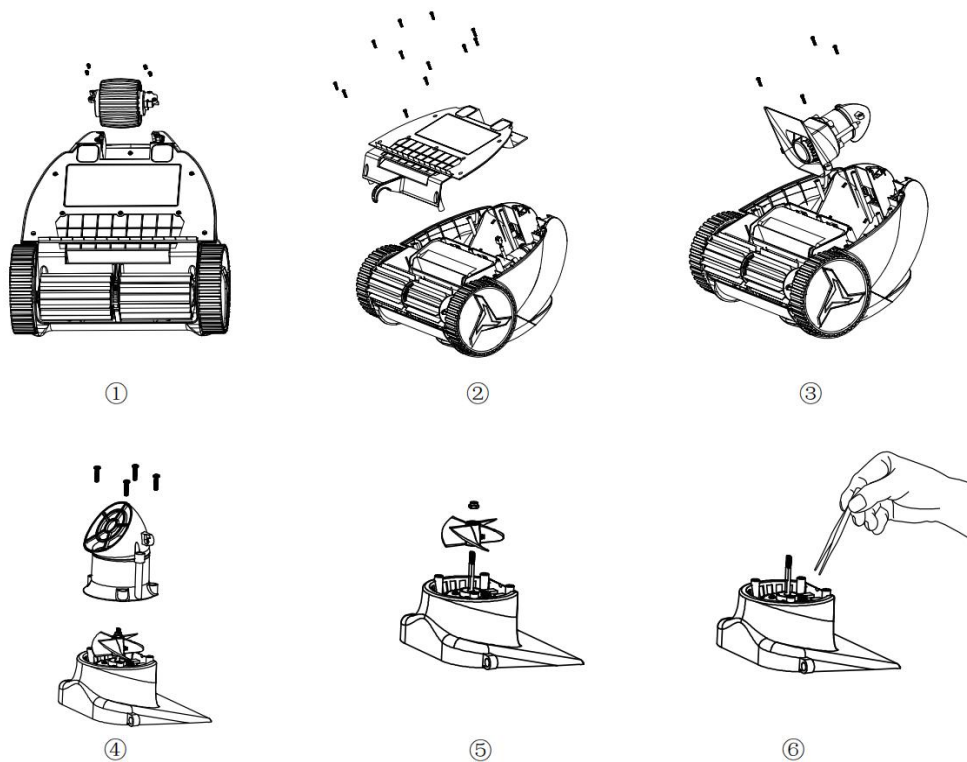

- ① Remove the rear wheel fixing screw and take out the rear wheel.
- ② Remove the fixing screws of the bottom cover and take out the bottom cover.
- ③ Remove the fixing screws of the water pump motor cover assembly.
- ④ Remove the screws that fix the air deflector and take out the air deflector.
- ⑤ Remove the impeller fixing screws and take out the impeller.

Note: Please wear gloves when removing the impeller to prevent injury from sharp edges.

- ⑥ Clean the impeller debris and reassemble all the above parts in order.

Note: If you have any difficulty with impeller maintenance, contact the dealer for assistance.

SECTION 4. TROUBLESHOOTING

<i>Failure</i>	<i>Possible reason</i>	<i>Solution</i>
<i>Charging failure</i>	<i>Debris on the electrode of charging head (Non-failure)</i>	<i>Clean debris</i>
	<i>The temperature is higher than 50°C</i>	<i>Place the robot in 6~35°C temperature environment</i>
	<i>The charging kit is damaged</i>	<i>Replace the charging kit</i>
<i>Switching on failure</i>	<i>The power switch is OFF (Non-failure)</i>	<i>Turn on the power</i>
	<i>Wrong operation (Non-failure)</i>	<i>Hold  the button for 3 seconds</i>
	<i>No power in the battery (Non-failure)</i>	<i>Get the robot fully charged</i>
<i>Not working (not moving, not pumping)</i>	<i>Low battery (Non-failure)</i>	<i>Get the robot fully charged</i>
	<i>Out of water (Non-failure)</i>	<i>Make sure the robot under water and the indicator lights are on</i>
	<i>Full load of filter basket (Non-failure)</i>	<i>Clean filter basket</i>
<i>Moving but not pumping</i>	<i>The impeller gets stuck</i>	<i>Check whether there is too much debris in the guide ring, affecting the rotation of the impeller. (Please switch the power to OFF before</i>

		<i>operation, to avoid injuries caused by the impeller rotation)</i>
	<i>Full load of filter basket (Non-failure)</i>	<i>Clean filter basket</i>
	<i>Water inlet is blocked(Non-failure)</i>	<i>Take out of filter basket and clean water inlet</i>
	<i>Battery low (Non-failure)</i>	<i>Get the robot fully charged</i>
<i>Pumping but not moving</i>	<i>The moving motor gets stuck</i>	<i>Please contact the dealer for a replacement</i>
	<i>The track is deviated and stuck (Non-failure)</i>	<i>Turn the robot upside down and roll the track forward and backward to restore the track</i>
	<i>Track is damaged</i>	<i>Replace track</i>
	<i>Scrubber gets stuck (Non-failure)</i>	<i>Clean scrubber</i>
	<i>The robot gets stuck by obstacle and shut down for auto-protection (Non-failure)</i>	<i>Remove the obstacle and restart</i>
	<i>Full load of filter basket (Non-failure)</i>	<i>Clean filter basket</i>
<i>Not climbing</i>	<i>Under floor cleaning mode (Non-failure)</i>	<i>Turn to overall cleaning mode</i>

	The impeller is stuck	Check whether there is too much debris in the guide ring, affecting the rotation of the impeller. (Please switch the power to OFF before operation, to avoid injuries caused by the impeller rotation)
	Full load of filter basket (Non-failure)	Clean filter basket
	Water inlet is blocked (Non-failure)	Take out of filter basket and clean the water inlet
Poor cleaning capability	Battery low (Non-failure)	Get the robot fully charged
	The impeller is stuck	Remove any debris or hair in the guide ring
	Full load of filter basket (Non-failure)	Clean filter basket
	Water inlet blocked (Non-failure)	Take out of filter basket and clean the water inlet
	Scrubber is damaged	Replace scrubber
	Filter basket is damaged	Replace filter basket
Unusual non-stop	Software failure	Switch the power to OFF and then ON
Error	a. Left drive failure b. Right drive failure c. Water pump failure	Switch the power to OFF and then ON to check if the error disappears, if not, please contact the dealers

	<i>d. Infrared sensor failure</i> <i>e. Water sensor failure</i>	
--	---	--

Note:

- 1. Do not use the robot when people or animals are in the pool.*
- 2. Charger **MUST BE DISCONNECTED** before performing any maintenance on the robot.*
- 3. Contact dealer for problems not include in Trouble Shooting Guide.*
- 4. Normally, the robot will stop at the poolside when it encounters any failure or when the battery is less than 15%.*
- 5. If the robot is malfunctioning, the light on the control panel flashes red. Restart the robot might remove the error warning and allow operation, if error occurs again, please check troubleshooting guide.*

Indoor



For switch power supply indoor use only.

Recycling

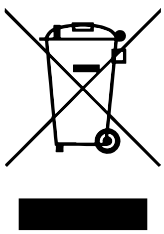

The robot contains a Lithium-ion battery, which should be recycled by qualified battery electronics recyclers. Recycling of batteries and battery-containing products benefits the environment and human health.

Do NOT disassemble or dispose of the battery in the rubbish or municipal recycling bins.

Warranty Exclusions

Warranty is invalid if any of the following apply:

- Incorrect operation of the unit by not following correct instructions.*
- Damage caused to the robot due to misuse or damage caused by any other means than manufacturer defect.*
- If robotic pool cleaner is repaired or serviced by an unauthorized dealer or service station.*
- If an unauthorized service station damaged battery seal.*
- If you overcharge the battery by using a non-specified input power adapter.*
- If you cause a fault in the operation of the machine by using non-specified accessories.*

Version: XA-FLR-A1