

SWIMMING POOL HEAT PUMP UNIT

Installation & Instruction Manual

CONTENTS

1. Preface	1
2. Specifications	2
2.1 Performance Data of Swimming Pool Heat Pump Unit	2
2.2 Dimensions for Swimming Pool Heat Pump Unit	3
3. Installation and Connection	6
3.1 Installation of System	6
3.2 Swimming Pool Heat Pumps Location	7
3.3 How Close to Your Pool?	7
3.4 Swimming Pool Heat Pumps Plumbing	8
3.5 Swimming Pool Heat Pumps Electrical Wiring	9
3.6 Initial Start-up of the Unit	9
4. Usage and Operation	10
4.1 Function of the controller	10
4.2 Usage of the controller	11
4.3 Parameter table	13
4.4 Multifunction table	14
5. Maintenance and Inspection	15
6. Appendix	16

1. PREFACE

- In order to provide our customers with quality, reliability and versatility, this product has been made to strict production standards. This manual includes all the necessary information about installation, debugging, discharging and maintenance. Please read this manual carefully before you open or maintain the unit. The manufacture of this product will not be held responsible if someone is injured or the unit is damaged, as a result of improper installation, debugging, or unnecessary maintenance. It is vital that the instructions within this manual are adhered to at all times. The unit must be installed by qualified personnel.
- The unit can only be repaired by qualified installer centre, personnel or an authorised dealer.
- Maintenance and operation must be carried out according to the recommended time and frequency, as stated in this manual.
- Use genuine standard spare parts only.
Failure to comply with these recommendations will invalidate the warranty.
- Swimming Pool Heat Pump Unit heats the swimming pool water and keeps the temperature constant. For split type unit, The indoor unit can be Discretely hidden or semi-hidden to suit a luxury house.

Our heat pump has following characteristics:

1 Durable

The heat exchanger is made of PVC & Titanium tube which can withstand prolonged exposure to swimming pool water.

2 Installation flexibility

The unit can be installed outdoors or indoors.

3 Quiet operation

The unit comprises an efficient rotary/ scroll compressor and a low-noise fan motor, which guarantees its quiet operation.

4 Advanced controlling

The unit includes micro-computer controlling, allowing all operation parameters to be set. Operation status can be displayed on the LED wire controller. Remote controller can be chosen as future option.

2.SPECIFICATION

2.1 Performance data of Swimming Pool Heat Pump Unit

*** REFRIGERANT : R410A

UNIT		565NR015	565NR020
Heating capacity (24/19℃)	kW	5.36	7.74
	Btu/h	18224	26316
Heating Power Input	kW	1.05	1.48
Running Current	A	4.9	6.6
Power Supply		230V~/50Hz	230V~/50Hz
Compressor Quantity		1	1
Compressor		rotary	rotary
Fan Number		1	1
Fan Power Input	W	90	90
Fan Rotate Speed	RPM	850	850
Fan Direction		horizontal	horizontal
Noise	dB(A)	50	52
Water Connection	mm	50	50
Water Flow Volume	m ³ /h	2.3	3
Water Pressure Drop(max)	kPa	2.4	3.2
Unit Net Dimensions(L/W/H)	mm	See the drawing of the units	
Unit Ship Dimensions(L/W/H)	mm	See package lable	
Net Weight	kg	see nameplate	
Shipping Weight	kg	see package label	

UNIT		565NR030	565NR035
Heating capacity (24/19℃)	kW	10.31	11.73
	Btu/h	35054	39882
Heating Power Input	kW	1.89	2.43
Running Current	A	8.46	12.23
Power Supply		230V~/50Hz	230V~/50Hz
Compressor Quantity		1	1
Compressor		rotary	rotary
Fan Number		1	1
Fan Power Input	W	120	120
Fan Rotate Speed	RPM	850	850
Fan Direction		horizontal	horizontal
Noise	dB(A)	54	54
Water Connection	mm	50	50
Water Flow Volume	m ³ /h	4.5	5.3
Water Pressure Drop(max)	kPa	6	10
Unit Net Dimensions(L/W/H)	mm	See the drawing of the units	
Unit Ship Dimensions(L/W/H)	mm	See package lable	
Net Weight	kg	see nameplate	
Shipping Weight	kg	see package label	

Heating: Outdoor airtemp: 24℃/19℃, Inlet watertemp:26℃

2.SPECIFICATION

565NR015

Unit: mm

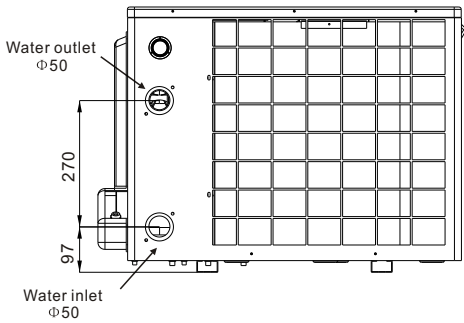
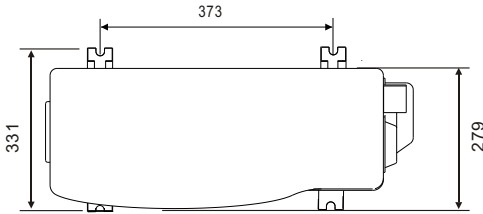
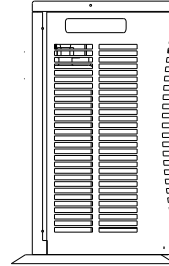
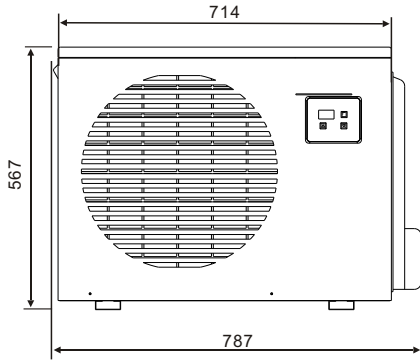

2.SPECIFICATION

565NR020

Unit: mm

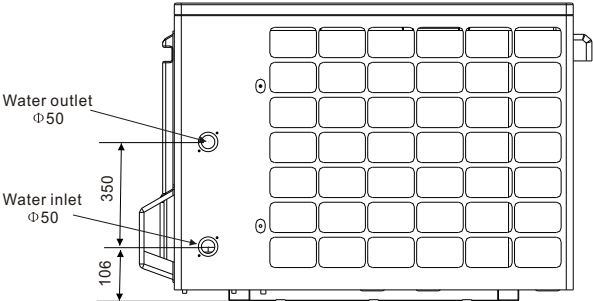
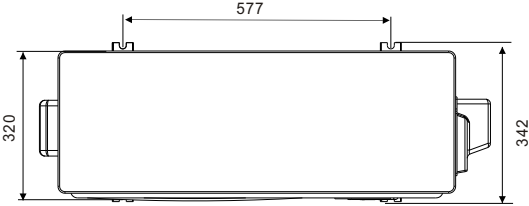
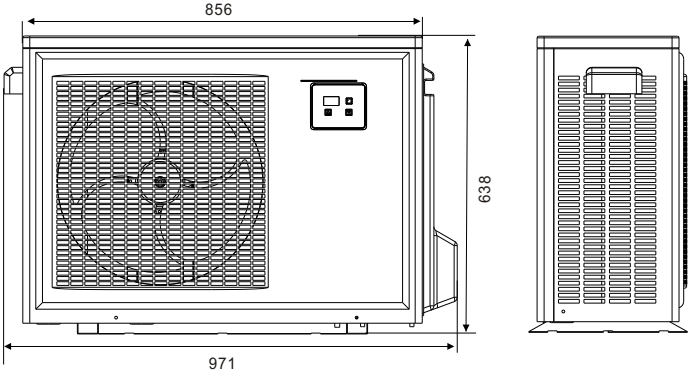

2.SPECIFICATION

565NR030/565NR035

Unit: mm

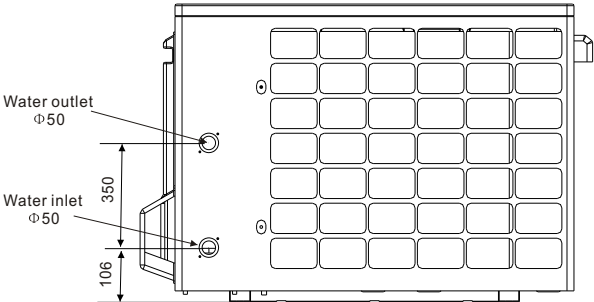
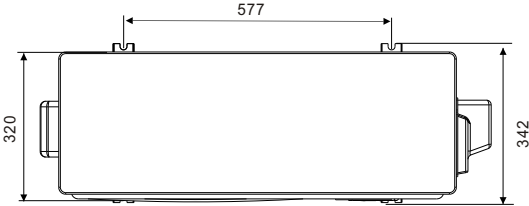
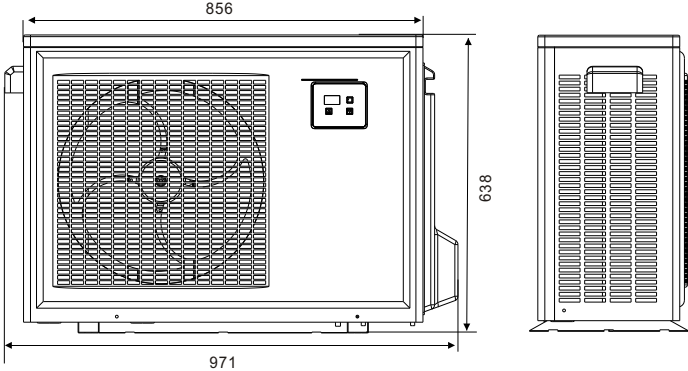

3. INSTALLATION AND CONNECTION

3.1 Installation illustration

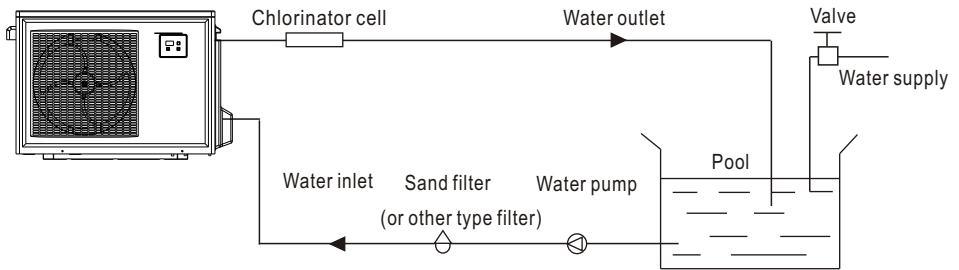

Installation items:

The factory only provides the main unit and the water unit; the other items in the illustration are necessary spare parts for the water system, that provided by users or the installer.

Attention:

Please follow these steps when using for the first time

1. Open valve and charge water.
2. Make sure that the pump and the water-in pipe have been filled with water.
3. Close the valve and start the unit.

ATTN: It is necessary that the water-in pipe is higher than the pool surface.

The schematic diagram is for reference only. Please check the water inlet/outlet label on the heat pump while plumbing installation.

3. INSTALLATION AND CONNECTION

3.2 Swimming Pool Heat Pumps Location

The unit will perform well in any outdoor location provided that the following three factors are presented:

1. Fresh Air - 2. Electricity - 3. Pool filter piping

The unit may be installed virtually anywhere outdoors. For indoor pools please consult the supplier. Unlike a gas heater, it has no draft or pilot light problem in a windy area.

DO NOT place the unit in an enclosed area with a limited air volume, where the units discharge air will be re-circulated.

DO NOT place the unit to shrubs which can block air inlet. These locations deny the unit of a continuous source of fresh air which reduces its efficiency and may prevent adequate heat delivery.

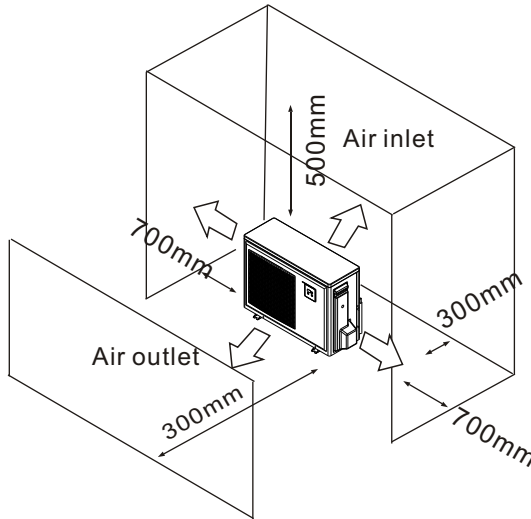

3.3 How Close To Your Pool?

Normally, the pool heat pump is installed within 7.5 metres of the pool. The longer the distance from the pool, the greater the heat loss from the piping. For the most part, the piping is buried. Therefore, the heat loss is minimal for runs of up to 15 meters (15 meters to and from the pump = 30 meters total), unless the ground is wet or the water table is high. A very rough estimate of heat loss per 30 meters is 0.6 kW-hour, (2000 BTU) for every 5 °C difference in temperature between the pool water and the ground surrounding the pipe, which translates to about 3% to 5% increase in run time.

3. INSTALLATION AND CONNECTION

3.4 Swimming Pool Heat Pumps Plumbing

The Swimming Pool Heat Pumps exclusive rated flow titanium heat exchanger requires no special plumbing arrangements except bypass (please set the flow rate according to the nameplate). The water pressure drop is less than 10kPa at max. flow rate. Since there is no residual heat or flame temperatures, the unit does not need copper heat sink piping. PVC pipe can be run straight into the unit.

Location: Connect the unit in the pool pump discharge (return) line downstream of all filter and pool pumps, and upstream of any chlorinators, ozonators or chemical pumps.

Standard model has slip glue fittings which accept 32mm or 50 mm PVC pipe for connection to the pool or spa filtration piping. By using a 50NB to 40NB you can plumb 40NB

Give serious consideration to adding a quick coupler fitting at the unit inlet and outlet to allow easy draining of unit for winterizing and to provide easier access should servicing be required.

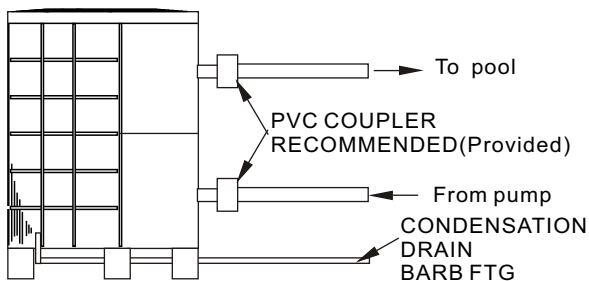

Condensation: Since the Heat pump cools down the air about 4 -5°C, water may condense on the fins of the horseshoe shaped evaporator. If the relative humidity is very high, this could be as much as several litres an hour. The water will run down the fins into the basepan and drain out through the barbed plastic condensation drain fitting on the side of the basepan. This fitting is designed to accept 20mm clear vinyl tubing which can be pushed on by hand and run to a suitable drain. It is easy to mistake the condensation for a water leak inside the unit.

NB: A quick way to verify that the water is condensation is to shut off the unit and keep the pool pump running. If the water stops running out of the basepan, it is condensation. AN EVEN QUICKER WAY IS to TEST THE DRAIN WATER FOR CHLORINE - if there is no chlorine present, then it's condensation.

3. INSTALLATION AND CONNECTION

3.5 Swimming Pool Heat Pumps Electrical Wiring

NOTE: Although the unit heat exchanger is electrically isolated from the rest of the unit, it simply prevents the flow of electricity to or from the pool water. Grounding the unit is still required to protect you against short circuits inside the unit. Bonding is also required.

The unit has a separate molded-in junction box with a standard electrical conduit nipple already in place. Just remove the screws and the front panel, feed your supply lines in through the conduit nipple and wire-nut the electric supply wires to the three connections already in the junction box (four connections if three phase). To complete electrical hookup, connect Heat Pump by electrical conduit, UF cable or other suitable means as specified (as permitted by local electrical authorities) to a dedicated AC power supply branch circuit equipped with the proper circuit breaker, disconnect or time delay fuse protection.

Disconnect - A disconnect means (circuit breaker, fused or un-fused switch) should be located within sight of and readily accessible from the unit. This is common practice on commercial and residential air conditioners and heat pumps. It prevents remotely-energizing unattended equipment and permits turning off power at the unit while the unit is being serviced.

3.6 Initial startup of the Unit

NOTE- In order for the unit to heat the pool or spa, the filter pump must be running to circulate water through the heat exchanger.

Start up Procedure - After installation is completed, you should follow these steps:



1. Turn on your filter pump. Check for water leaks and verify flow to and from the pool.
2. Turn on the electrical power supply to the unit, then press the key ON/OFF of wire controller. It should start in several seconds.
3. After running a few minutes make sure the air leaving the top(side) of the unit is cooler (Between 5-10 °C)
4. With the unit operating turn the filter pump off. The unit should also turn off automatically,
5. Allow the unit and pool pump to run 24 hours per day until desired pool water temperature is reached. When the water-in temperature reach setting, The unit just shuts off. The unit will now automatically restart (as long as your pool pump is running) when the pool temperature drops more than 2°C below set temperature.

Time Delay- The unit is equipped with a 3 minute built-in solid state restart delay included to protect control circuit components and to eliminate restart cycling and contactor chatter. This time delay will automatically restart the unit approximately 3 minutes after each control circuit interruption. Even a brief power interruption will activate the solid state 3 minute restart delay and prevent the unit from starting until the 5 minute countdown is completed. Power interruptions during the delay period will have no effect on the 3 minute countdown.

4.USAGE

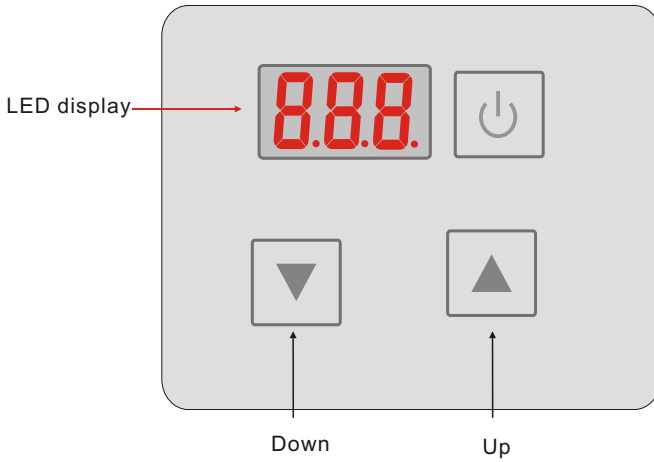
4.1 Function of wire controller



Key	Key name	Key function
	ON/OFF	Press this key to turn on/off the unit.
	Up	Press this key to select the upward option or increase the parameter value.
	Down	Press this key to select the downward option or decrease the parameter value.

4.USAGE

4.2 Usage of wire controller

4.2.1 TurnON/OFF the unit

When the unit is off, press the key “⏻” and hold on for 0.5s to turn on the unit;
When the unit is on, press the key “⏻” and hold on for 0.5s to turn off the unit;

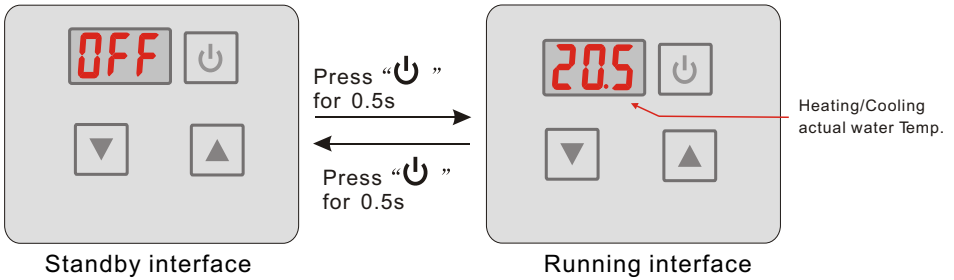

4.2.2 Setting temperature

In the running interface, press “▲” or “▼” then the current mode target-temperature flashes, then press “▲” to increase the temp.value, or press “▼” to decrease it. Press “⏻” will not save setting parameter but back to the main interface:

Attention: If there is no operation for 5s, system would remember parameter setting and back to the main interface.

In the main interface, press “▲” for 2s you can see the outlet temp. The parameter is then flashed and the display is back to the main interface after 10s.

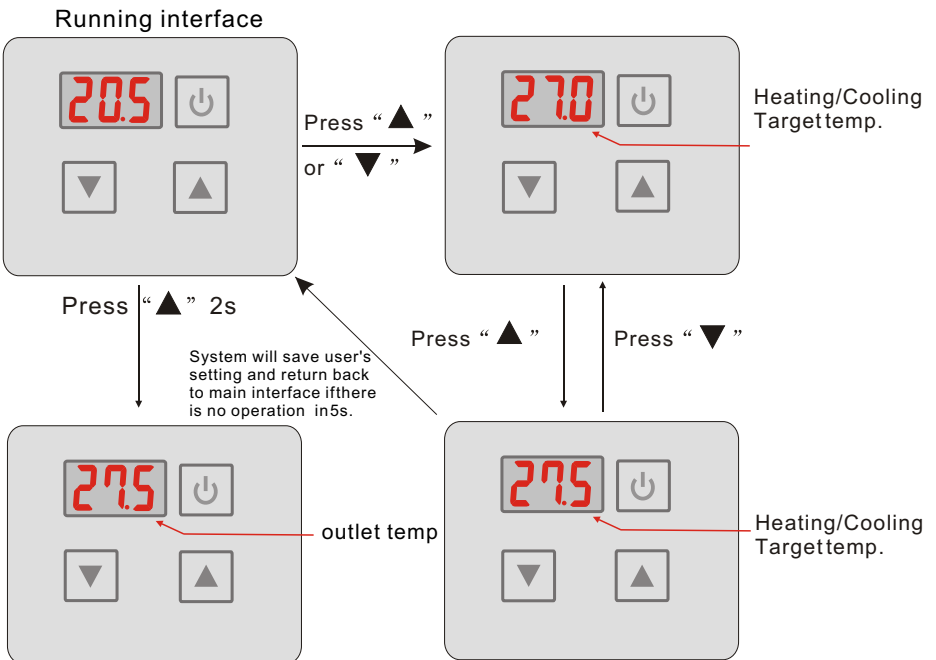

4.USAGE

4.2.3 Mode switch

In the main interface,press “▲” and “▼” for 0.5s can set the mode,press “▲” or “▼” to change the current mode,you can switch different modes of colling, heating and automode.

If there is no operation for 5s system will save the current mode and back to the main interface, press “⏻” can not save setting

The modes switching is useless of the unit you buy is singel-cold/single-heat unit

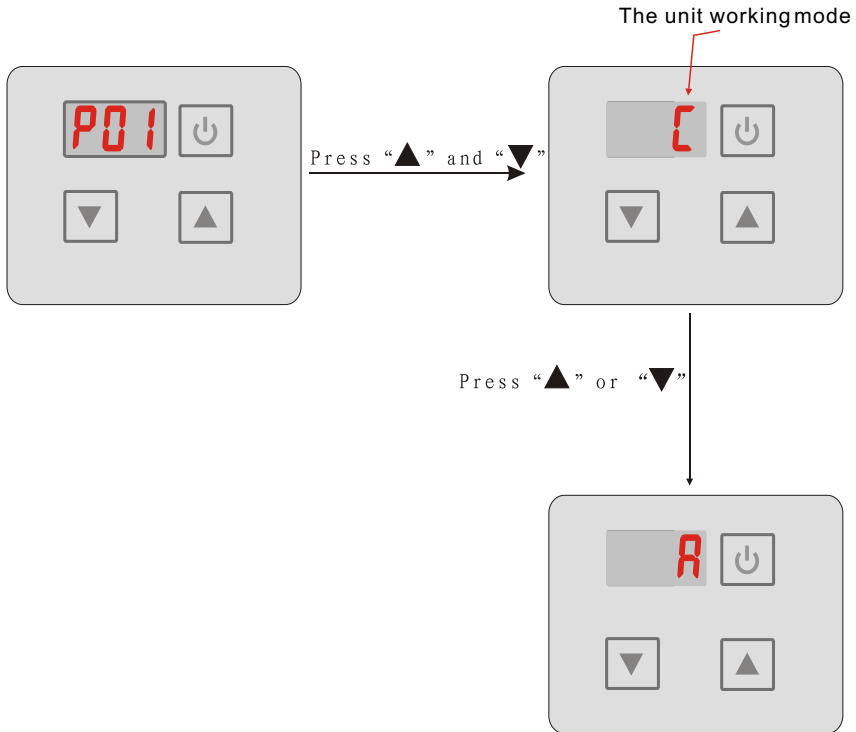

4.2.4 Keyboard lock

To avoid mis-operations, please lock the controller after parameter setting.

At the main interface, pressing “⏻” for 5 seconds,when hearing one sound, the keyboard is locked.

When the keyboard is locked, pressing “⏻” for 5 seconds. when hearing one sound, the keyboard lock is open.

NOTES: When the unit is in alarming state, the key lock can be removed automaticly.

4. USAGE

4.2.5 Malfunction display

There will be malfunction code showing on the controller screen when relative malfunction occurs.

If there are more than one malfunctions occurs at the same time, you can check the current error codes list by pressing “▲” or “▼” key.

You can refer to the malfunction table to find out the failure cause and solution.

For example:

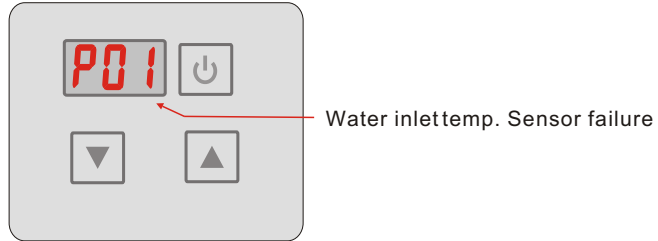

4.3 Parameter table

Meaning	Default	Remarks
Set-point of colling mode target temp.	27°C	Ajustable
Set-point of heating mode target temp.	27°C	Ajustable
Set-point of auto mode target temp.	27°C	Ajustable

4.USAGE

4.4.Malfunction Table

The common failure cause and solution.

Malfunction	Display	Cause	Solution
Water inlet temp.Sensor failure	P01	The water inlet temp.Sensor is open or shortcircuit	Check or change thewater inlet temp. Sensor
Water outlet temp.Sensor failure	P02	The water outlet temp.sensor is open or shortcircuit	Check or change thewater outlet temp. Sensor
Ambient temp. Sensor failure	P04	The ambient temp. sensor is open or shortcircuit	Check or change the ambient temp. Sensor
Pipe temp. Sensor failure	P05	The pipe temp. sensor is open or short circuit	Check or change thepipe temp. Sensor
Evaporator temp.Sensor failure	P07	The evaporator temp. Sensor is open or shortcircuit	Check or change the evaporator temp. Sensor
Exhaust temp. Sensor failure	P08	The exhaust temp. Sensor is open or short circuit	Check or change theexhaust temp. Sensor
High pressure protect	E01	The exhaust pressure is high , high pressure switch action	Check high pressure switch and cooling return circuit
Low pressure protect	E02	The suction pressure is low, Low pressure switch action	Check low pressure switchand cooling return circuit
Flow switch failure	E03	No water or litterwater in water system	Check the flow volume ,water pump is failure ornot
Temp. is too much different between water-inlet and outlet	E06	Water flow volumenot enough, Water system pressure difference is small	Check the flow volume ,water system is jammed ornot
Antifreezing under cooling mode	E07	Water flow volumenot enough	Check the flow volume ,water system is jammed ornot
The primary anti-freezing protection start.	E19	Ambient temperature is too low	
The second anti-freezing protection start	E29	Ambient temperature is too low	
Communication failure	E08	Communication failure between remote wire controller andmain board	Check the wire connection between remote wire controller andmain board

5. MAINTENANCE AND INSPECTION

- Check the water supply device and the release often. You should avoid the condition of no water or air entering into system, as this will influence unit's performance and reliability. You should clear the pool/spa filter regularly to avoid damage to the unit as a result of the dirty or clogged filter.
- The area around the unit should be dry, clean and well ventilated. Clean the side heating exchanger regularly to maintain good heat exchange and conserve energy.
- The operation pressure of the refrigerant system should only be serviced by a certified technician.
- Check the power supply and cable connection often. Should the unit begin to operate abnormally, switch it off and contact the qualified technician.
- Discharge all water in the water pump and water system, so that freezing of the water in the pump or water system does not occur. You should discharge the water at the bottom of the water pump if the unit will not be used for an extended period of time. You should check the unit thoroughly and fill the system with water fully before using it for the first time after a

6.APPENDIX

1.Connection of PCB illustration

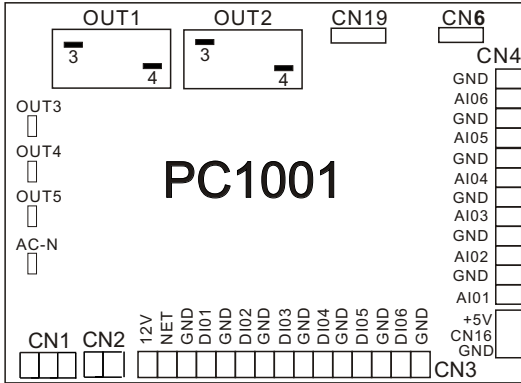

Connections explanation:

No.	Symbol	Meaning
1	OUT1	Compressor of system1 (220-230VAC)
2	OUT2	Water pump (220-230VAC)
3	OUT3	4way valve (220-230VAC)
4	OUT4	Fan motor (220-230VAC)
5	OUT5	No use
6	AC-N	Neutral wire
7	NET GND 12V	Wire controller
8	DI01 GND	On/Off Switch(input)
9	DI02 GND	Flow switch (input)
10	DI03 GND	Low pressure switch
11	DI04 GND	High pressure switch
12	DI05 GND	No use
13	DI06 GND	No use
14	AI01 GND	Suction temp.(input)
15	AI02 GND	Water in temp.(input)
16	AI03 GND	Water out temp.(input)
17	AI04 GND	Coil Temp. (input)
18	AI05 GND	Ambient temp.(input)
19	AI06 GND	Ajustable fan speed/Exhaust temperature
20	CN1	Primary transformer
21	CN2	Secondary transformer
22	CN6	No use
23	CN19	No use
24	5V CN16 GND	No use

6.APPENDIX

Caution & Warning

1. The unit can only be repaired by qualified installer centre personnel or an authorised dealer. (for Europe market)
2. This appliance is not intended for use by persons (including children) with reduced physical sensory or mental capabilities, or lack of experience and knowledge, unless they have been given supervision or instruction concerning use of the appliance by a person responsible for their safety. (for Europe market)
Children should be supervised to ensure that they do not play with the appliance.
3. Please make sure that the unit and power connection have good earthing, otherwise may cause electrical shock.
4. If the supply cord is damaged, it must be replaced by the manufacturer or our service agent or similarly qualified person in order to avoid a hazard.
5. Directive 2002/96/EC (WEEE):
The symbol depicting a crossed-out waste bin that is underneath the appliance indicates that this product, at the end of its useful life, must be handled separately from domestic waste, must be taken to a recycling centre for electric and electronic devices or handed back to the dealer when purchasing an equivalent appliance.
6. Directive 2002/95/EC (RoHS): This product is compliant with directive 2002/95/EC (RoHS) concerning restrictions for the use of harmful substances in electric and electronic devices.
7. The unit CANNOT be installed near the flammable gas. Once there is any leakage of the gas, fire can occur.
8. Make sure that there is circuit breaker for the unit, lack of circuit breaker can lead to electrical shock or fire.
9. The heat pump located inside the unit is equipped with an over-load protection system. It does not allow for the unit to start for at least 3 minutes from a previous stoppage.
10. The unit can only be repaired by the qualified personnel of an installer center or an authorized dealer. (for North America market)
11. Installation must be performed in accordance with the NEC/CEC by authorized person only. (for North America market)
12. USE SUPPLY WIRES SUITABLE FOR 75°C.
13. Caution: Single wall heat exchanger, not suitable for potable water connection.

6.APPENDIX

(2) Cable specification

1. Single phase unit

Nameplate maximum current	Phase line	Earth line	MCB	Creepage protector	Signal line
No more than 10A	$2 \times 1.5\text{mm}^2$	1.5mm^2	20A	30mA less than 0.1 sec	$n \times 0.5\text{mm}^2$
10~16A	$2 \times 2.5\text{mm}^2$	2.5mm^2	32A	30mA less than 0.1 sec	
16~25A	$2 \times 4\text{mm}^2$	4mm^2	40A	30mA less than 0.1 sec	
25~32A	$2 \times 6\text{mm}^2$	6mm^2	40A	30mA less than 0.1 sec	
32~40A	$2 \times 10\text{mm}^2$	10mm^2	63A	30mA less than 0.1 sec	
40~63A	$2 \times 16\text{mm}^2$	16mm^2	80A	30mA less than 0.1 sec	
63~75A	$2 \times 25\text{mm}^2$	25mm^2	100A	30mA less than 0.1 sec	
75~101A	$2 \times 25\text{mm}^2$	25mm^2	125A	30mA less than 0.1 sec	
101~123A	$2 \times 35\text{mm}^2$	35mm^2	160A	30mA less than 0.1 sec	
123~148A	$2 \times 50\text{mm}^2$	50mm^2	225A	30mA less than 0.1 sec	
148~186A	$2 \times 70\text{mm}^2$	70mm^2	250A	30mA less than 0.1 sec	
186~224A	$2 \times 95\text{mm}^2$	95mm^2	280A	30mA less than 0.1 sec	

2. Three phase unit

Nameplate maximum current	Phase line	Earth line	MCB	Creepage protector	Signal line
No more than 10A	$3 \times 1.5\text{mm}^2$	1.5mm^2	20A	30mA less than 0.1 sec	$n \times 0.5\text{mm}^2$
10~16A	$3 \times 2.5\text{mm}^2$	2.5mm^2	32A	30mA less than 0.1 sec	
16~25A	$3 \times 4\text{mm}^2$	4mm^2	40A	30mA less than 0.1 sec	
25~32A	$3 \times 6\text{mm}^2$	6mm^2	40A	30mA less than 0.1 sec	
32~40A	$3 \times 10\text{mm}^2$	10mm^2	63A	30mA less than 0.1 sec	
40~63A	$3 \times 16\text{mm}^2$	16mm^2	80A	30mA less than 0.1 sec	
63~75A	$3 \times 25\text{mm}^2$	25mm^2	100A	30mA less than 0.1 sec	
75~101A	$3 \times 25\text{mm}^2$	25mm^2	125A	30mA less than 0.1 sec	
101~123A	$3 \times 35\text{mm}^2$	35mm^2	160A	30mA less than 0.1 sec	
123~148A	$3 \times 50\text{mm}^2$	50mm^2	225A	30mA less than 0.1 sec	
148~186A	$3 \times 70\text{mm}^2$	70mm^2	250A	30mA less than 0.1 sec	
186~224A	$3 \times 95\text{mm}^2$	95mm^2	280A	30mA less than 0.1 sec	

When the unit will be installed at outdoor, please use the cable which can against UV.

6.APPENDIX

565NR015

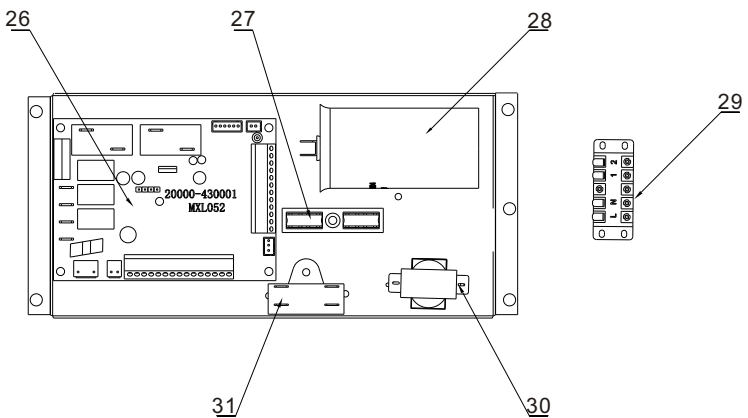
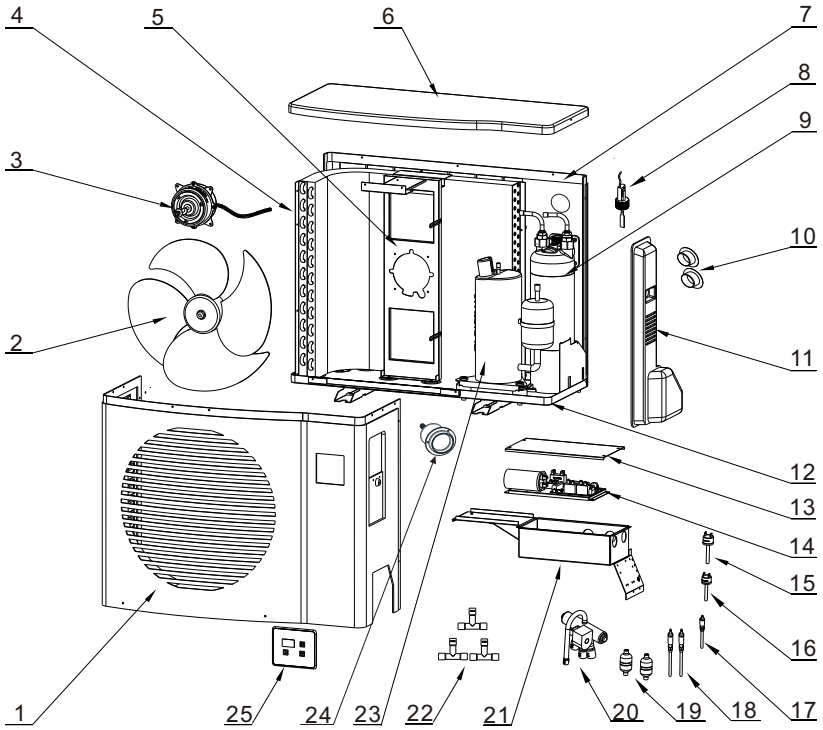

6.APPENDIX

No.	Code	Part name	Note	No.	Code	Part name	Note
1	32039-220002	front panel	1	21	32025-210186	electric appliance box	1
2	3401-2701	fan blade	1	22	2000-1460	Thread T-pipe	3
3	3401-3301	fan motor	1	23	20000-110174	compressor	1
4	32039-120009	finned heat exchanger	1	24	20000-280006	pressure gage	1
5	32025-210187	fan motor bracket	1	25	95005-310456	LED301	1
6	38008-220001	top cover	1	26	95005-310145	Pc1001	1
7	32025-220022	back net	1	27	2000-3909	2-terminal	1
8	20000-360005	water flow switch	1	28	2000-3504	compressor capacitor	1
9	32025-120039	heat exchanger	1	29	4000-3901	5-terminal	1
10	20000-220013	water proof cover	2	30	20000-370006	power transformer	1
11	38008-220004	Junction box body	1	31	2000-3506	fan motor capacitor	1
12	32039-210029	chassis	1	32			
13	32025-210157	electrical cover plate	1	33			
14	32039-210004	Electric box liner	1	34			
15	20000-360157	pressure switch	1	35			
16	2001-3605	pressure switch	1	36			
17	20000-140153	needle valve	1	37			
18	20000-140150	needle valve	2	38			
19	2000-1494	filter	2	39			
20	2004-1448	4-way valve	1	40			

6.APPENDIX

565NR020

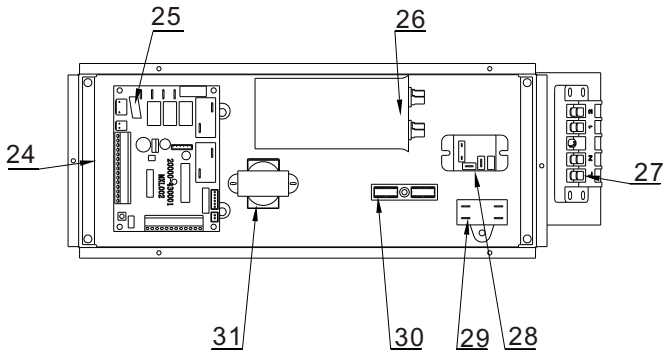
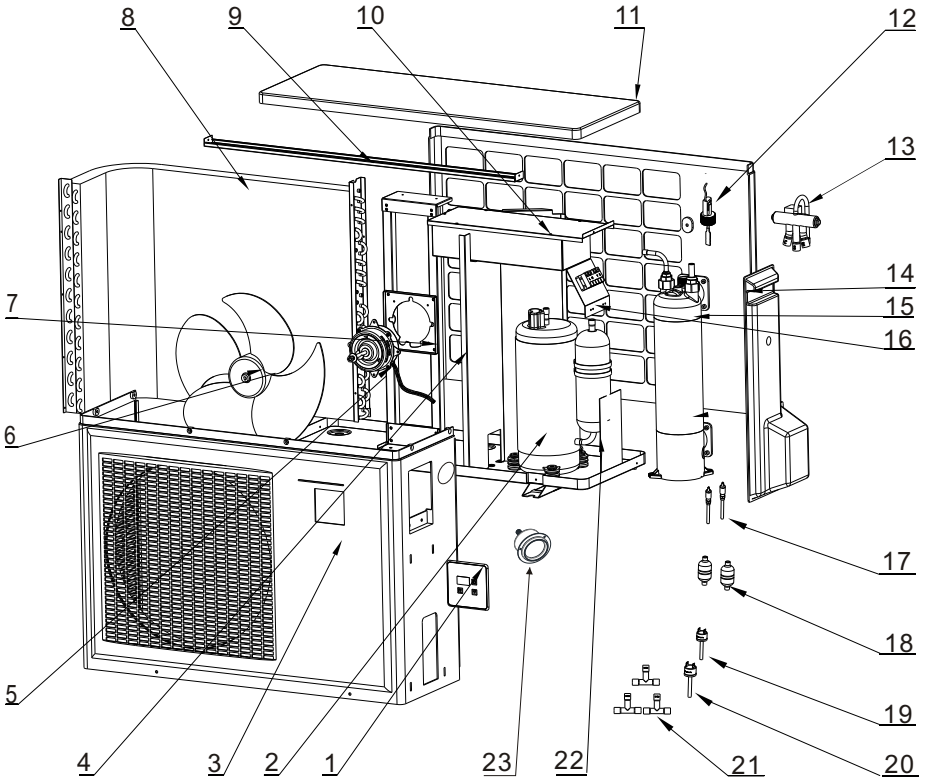

6.APPENDIX

No.	Code	Part name	Note	No.	Code	Part name	Note
1	95005-310456	LED301	1	21	2000-1460	Thread T-pipe	3
2	20000-110135	Compressor and fittings	1	22	32012-210382	Chassis	1
3	32012-210440	Front Plate	1	23	20000-280006	pressure gage	1
4	32012-210385	Middle Plate	1	24	32012-210388	electric appliance box	1
5	3401-3301	Fan Motor	1	25	95005-310145	Pc1001	1
6	3401-2701	Fan Blade	1	26	2000-3510	compressor capacitor	1
7	32012-210390	Fan Motor Support	1	27	4000-3901	5-terminal	1
8	32008-120039	Air Heat Exchanger	1	28	20000-360203	Relay	1
9	32012-210383	Supporting Plate	1	29	2000-3506	fan motor capacitor	1
10	32012-210386	Electrical Box Cover	1	30	2000-3909	2-terminal	1
11	5508-2201	Top Cover	1	31	20000-370006	transformer	1
12	20000-360005	Water Flow Switch	1	32	2000-3711	transformer	
13	2001-1418	4-way Valver and fittings	1	33			
14	5508-2203	Display Cover	1	34			
15	32012-120061	Water Heat Exchanger	1	35			
16	32012-210387	Electrical Box Cover	1	36			
17	20000-140150	Needle valve	2	37			
18	2004-1446	Filter(R410A)	2	38			
19	2001-3605	High Pressure Switch	1	39			
20	20000-360157	Low Pressure Switch	1	40			

6.APPENDIX

565NR030

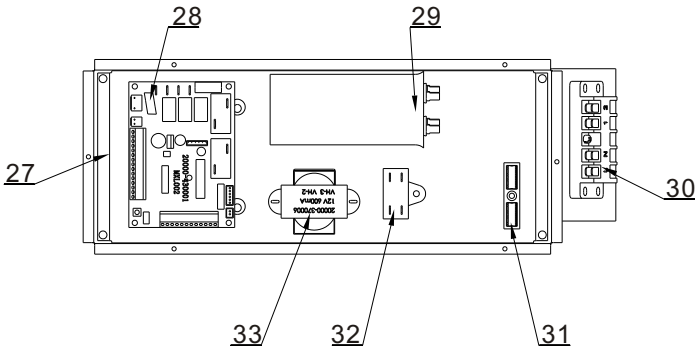
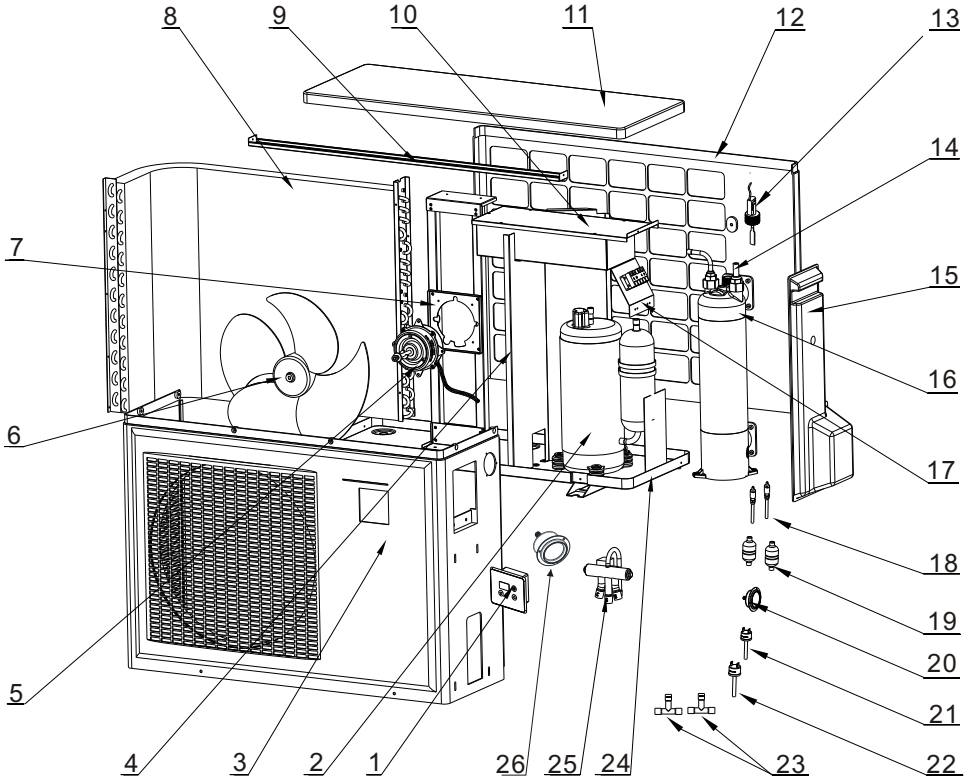

6.APPENDIX

No.	Code	Part name	Note	No.	Code	Part name	Note
1	95005-310456	LED display	1	21	2001-3605	Pressure Switch	1
2	20000-110231	Compressor	1	22	20000-360157	Pressure Switch	1
3	32012-210460	Front panel	1	23	2000-1460	3-way valve	2
4	32012-210462	Middle panel	1	24	32012-210461	Chassis	1
5	3404-3301	Fan Motor	1	25	2004-1437	4-way reverse valve	1
6	20000-270018	Axial fan	1	26	32012-210387	Electrical box	1
7	32012-210389	Fan motor holder	1	27	95005-310457	Pc1001 PCB controller	1
8	32012-120106	Evaporator	1	28	2000-3510	Compressor capacitor	1
9	32012-210383	Supporting panel	1	29	4000-3901	Terminal-5	1
10	32012-210386	Electrical box cover	1	30	2000-3909	Terminal-2	1
11	5508-2201	Top Cover	1	31	2000-3619	Relay	1
12	32012-210393	Back panel	1	32	2000-3501	Fan motor capacitor	1
13	20000-360005	Water flow switch	1	33	20000-370006	Transformer	1
14	2000-3242	Temp. sensor	4	34			
15	5508-2203	Handle	1	35			
16	32012-120056	Titanium heat exchanger	1	36			
17	32012-210386	Electrical lifed plate	1	37			
18	20000-140150	Needle valve	2	38			
19	2004-1445	Filter	2	39			
20	20000-280004	Pressure gage	1	40			

6.APPENDIX

565NR035

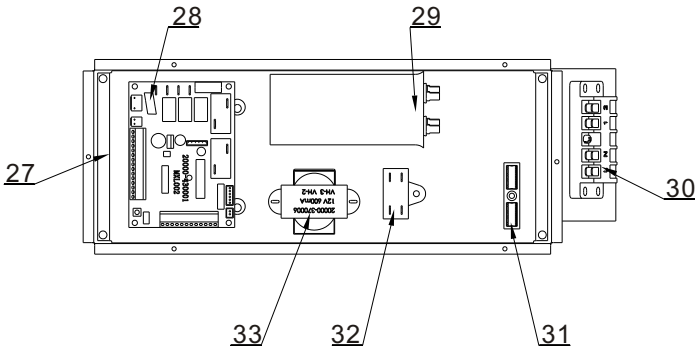
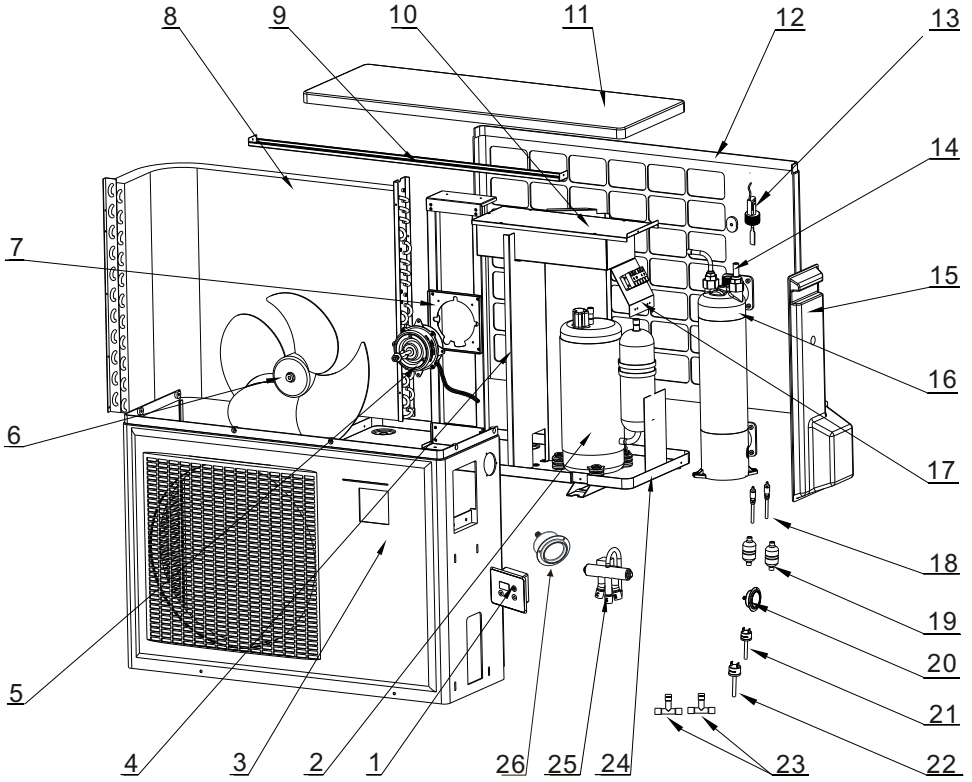

6.APPENDIX

No.	Code	Part name	Note	No.	Code	Part name	Note
1	95005-310456	LED display	1	21	2001-3605	Pressure Switch	1
2	20000-110237	Compressor	1	22	20000-360157	Pressure Switch	1
3	32012-210460	Front panel	1	23	2000-1460	3-way valve	2
4	32012-210462	Middle panel	1	24	32012-210461	Chassis	1
5	3404-3301	Fan Motor	1	25	2004-1437	4-way reverse valve	1
6	20000-270018	Axial fan	1	26	32012-210387	Electrical box	1
7	32012-210389	Fan motor holder	1	27	95005-310457	Pc1001 PCB controller	1
8	32012-120106	Evaporator	1	28	2000-3510	Compressor capacitor	1
9	32012-210383	Supporting panel	1	29	4000-3901	Terminal-5	1
10	32012-210386	Electrical box cover	1	30	2000-3909	Terminal-2	1
11	5508-2201	Top Cover	1	31	2000-3619	Relay	1
12	32012-210393	Back panel	1	32	2000-3501	Fan motor capacitor	1
13	20000-360005	Water flow switch	1	33	20000-370006	Transformer	1
14	2000-3242	Temp. sensor	4	34			
15	5508-2203	Handle	1	35			
16	32012-120089	Titanium heat exchanger	1	36			
17	32012-210386	Electrical lifed plate	1	37			
18	20000-140150	Needle valve	2	38			
19	2004-1445	Filter	2	39			
20	20000-280004	Pressure gage	1	40			

Note: _____

