

**LED pool light  
Intelligent Remote Controller**

# **OWNER'S MANUAL**

**PLP-REM**



**Spectra**vision™  
lighting

**Multi-functional Controller  
for Spectravision Pool Lights  
and 2 auxiliary circuits**



# Table of contents

Technical specifications	
General Specifications .....	Page 4
Logic board .....	Page 5
Installation Instructions	
Single PLP-REM unit .....	Page 6
Multiple PLP-REM installation .....	Page 7
Operation modes .....	Page 8
DIP switch functionalities .....	Page 9
Transmitter functions	
MODE 1: ON/OFF CONTROL .....	Page 10
MODE 2: PLC CONTROL .....	Page 10
Replacing transmitter keypad .....	Page 11
Pairing the handheld transmitter .....	Page 11
DMX 512 communication	
Single PLP-REM unit .....	Page 12
Multiple PLP-REM installation .....	Page 13
RS485 communication	
Single PLP-REM unit .....	Page 14
Multiple PLP-REM installation .....	Page 15
RS485 command set .....	Page 16
RESET procedure .....	Page 17
Troubleshooting .....	Page 18
Transmitter battery .....	Page 18
Pool light wiring instructions .....	Page 20

# Technical specifications

## General specifications

Input Voltage:	12VAC
Max rating "12VAC TO LAMPS" contact	60A / 12VAC
Max rating relay contact A & B	16A / 250 VAC
Max switching power A & B	4000VA
RF band	868 MHz
Ambient Air Temperature:	0°C to +40°C
Humidity	10% to 90% RH non condensing
Ingress protection rate:	IP54
IEC Protection Class:	Class II <input type="checkbox"/>

# Logic board

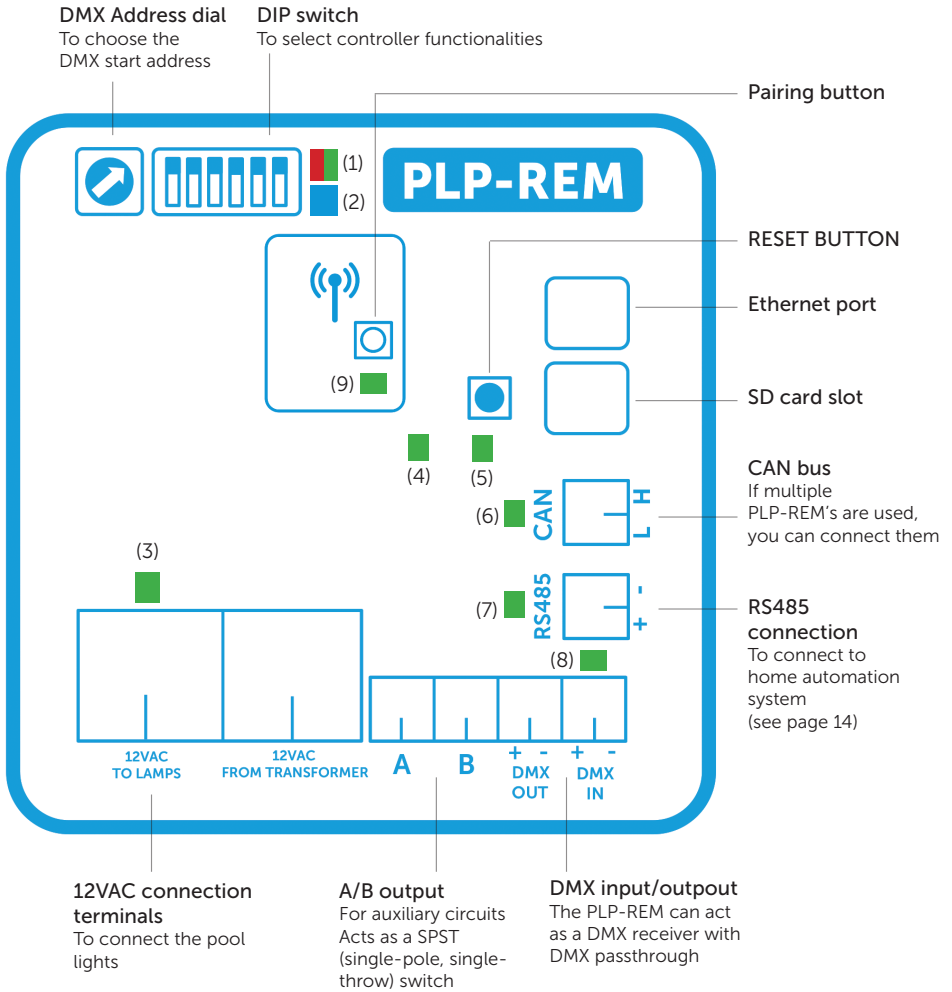

## Status LED's:

- (1) General status: Green = OK  
Red = error (see p.18)
- (2) RESET status (see page 17)
- (3) 12VAC to Pool lamps (Green = ON)
- (4) Switch A (Green = ON)
- (5) Switch B status (Green = ON)
- (6) CAN status
- (7) RS485 signal
- (8) DMX signal
- (9) Pairing status (see page 11)

# Installation Instructions

## Single PLP-REM unit

- Connect a 12VAC magnetic transformer to the "12VAC FROM TRANSFORMER" terminal of the PLP-REM.  
Connect the pool lights to the "12VAC TO LAMPS" terminal in the PLP-REM.
- Install the filter (©) (included in box) to the primary circuit (230VAC side) of the transformer
- The "12VAC TO LAMPS" relay contact has a max rating of 60A. Make sure the total power load does not exceed this ( $60A \times 12VAC = 720VA$ )

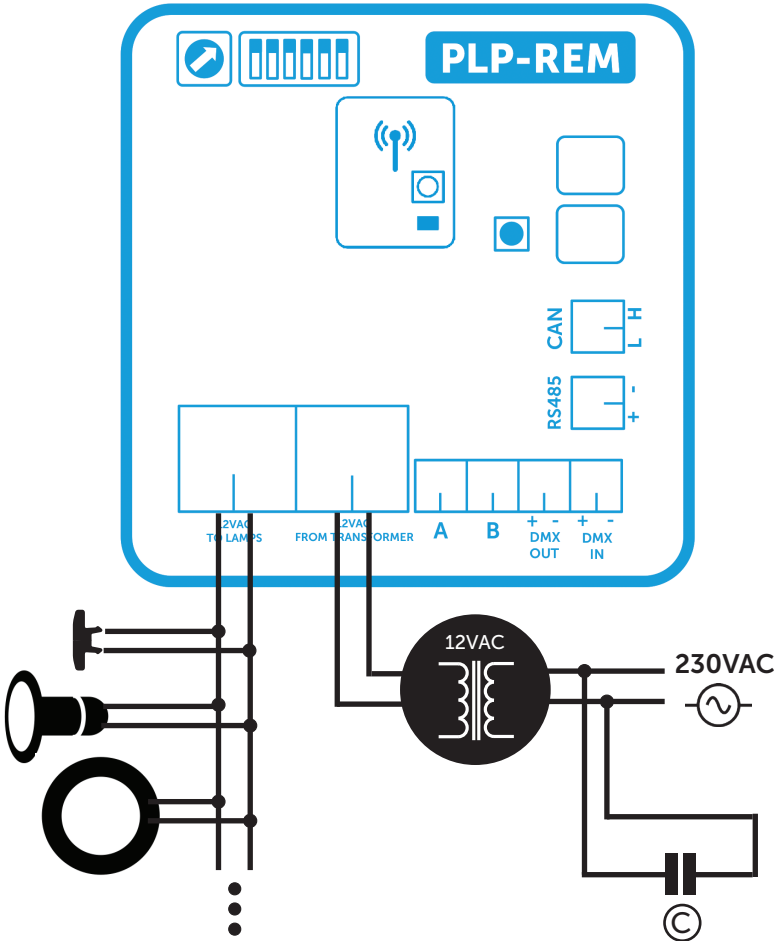

## Multiple PLP-REM installation

For extended installations (total lamp power > 720VA), multiple PLP-REM's can be linked together. This way, a perfect synchronisation of all pool lights is still guaranteed.

The PLP-REM's need to communicate to each other, to ensure all the lamps are in perfect sync. There are 2 options:

### 1) Connect Wirelessly

This is done automatically. Each PLP-REM has a built in wireless module that detects other PLP-REM's in the neighbourhood.

### 2) Connect Hardwired

Preferred if multiple PLP-REM's are at a very long distance from each-other

Connect the PLP-REM's with each other in PARALLEL:

Connect the CAN terminals of the first PLP-REM with the CAN terminal of the second PLP-REM.





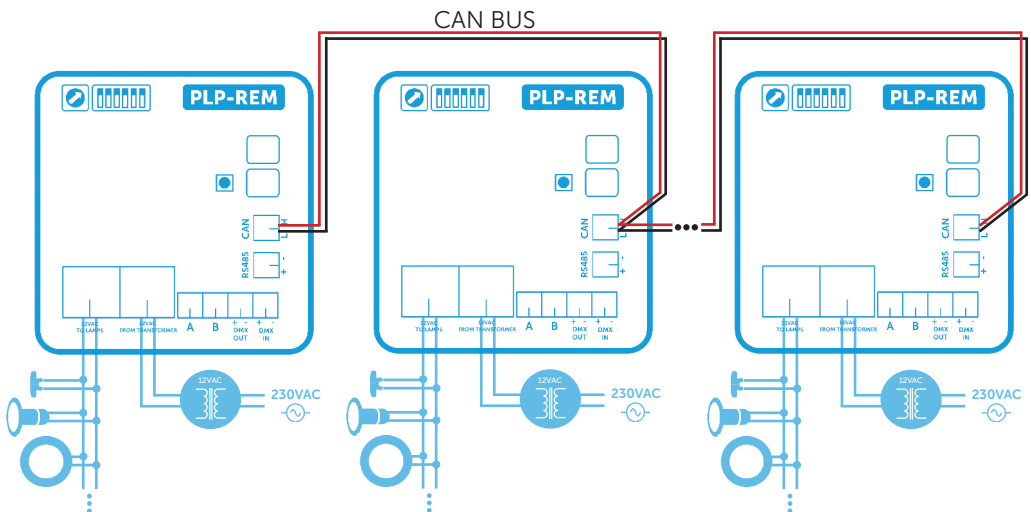



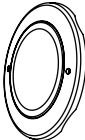

If more than 2 PLP-REM's are necessary, simply daisy chain each CAN terminal with the one from the next PLP-REM (see below)

Respect the polarity of the terminals! (CAN L & H)



## Operation Modes

The PLP-REM has 2 main operation modes: "ON/OFF control mode" & "PLC control mode". Each mode has its own functionalities:

	ON/OFF control	PLC control
Compatible lamps	 Adagio <sup>PRO</sup>  Adagio <sup>+</sup>  Moonlight	 Adagio <sup>PRO</sup>
Switch lamps ON/OFF	YES	YES
Change lamp color	YES <sup>(1)</sup>	YES <sup>(1)</sup>
Operate Relay A & B	YES	YES
Dimming lamps	NO	YES <sup>(1)</sup>
DMX control	NO	YES
RS485 control	YES <sup>(2)</sup>	YES
Dip switch setting	DIP 1 ON	DIP 1 OFF
Remote keypad type <sup>(3)</sup>	   	   

1) Only for RGB lamps

2) In ON/OFF control mode, only a few RS485 commands are available (see p 16)

3) Depending on which control mode is selected, the keypad of the transmitter needs to be changed



# DIP switch functionalities

The DIP switch on the main circuit board of the PLP-REM allows the user to customise the way the PLP-REM operates.

**⚠ CAUTION:** Always switch off the main power supply to the PLP-REM before changing the DIP switches

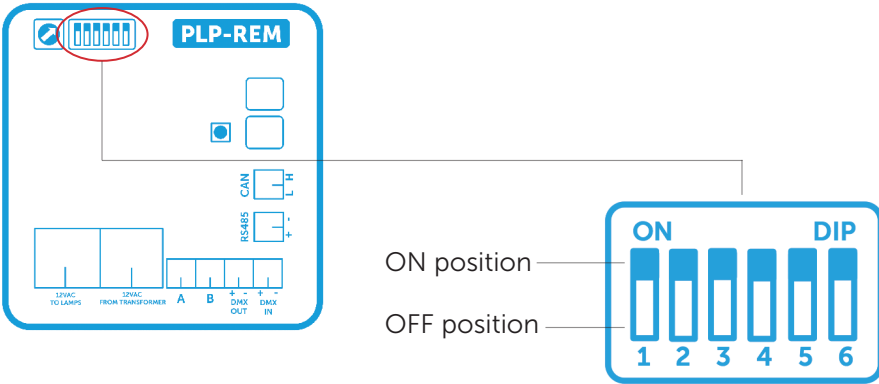

		DIP SWITCH					
function	setting	1	2	3	4	5	6
Mode of operation	ON/OFF	ON					
	PLC	OFF					
Relay A	PULSE mode		ON				
	TOGGLE mode		OFF				
Relay B	PULSE mode			ON			
	TOGGLE mode			OFF			
ON/OFF CONTROL pulse duration	SHORT				ON		
	LONG				OFF		
DMX	NO LOOP					ON	
	LOOP					OFF	
MASTER/SLAVE mode	SLAVE						ON
	MASTER						OFF

\* ON/OFF CONTROL pulse duration:

To change colors, the lamps need to switch OFF and then back ON.

With SHORT pulse duration, the switching transition is not noticeable and the lamps change color very smoothly (short pulse only possible for Adagio Pro RGB lamps)

# Transmitter functions

## MODE 1: PLC CONTROL (default mode)

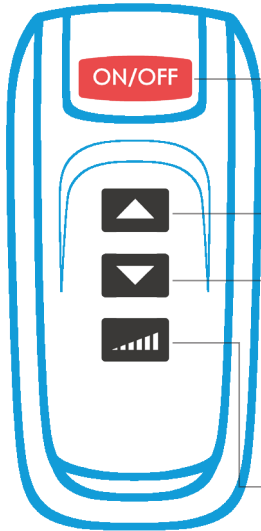

**Short push (< 1 sec):**

Toggle the lamp ON of OFF <sup>(1)</sup>

**Long push (> 2 sec<sup>(2)</sup>):**

All lamps & "12VAC TO LAMPS" relay are turned OFF <sup>(1)</sup>

**Short push:**

Go to next color program

**Long push:**

Toggle output A ON/OFF

**Short push:**

Go to the previous color program

**Long push:**

Toggle output B ON/OFF

**Short push:**

Select next dimming level:

100% -- 50% -- 25% ---> 100% -- ...

**Long push:**

Set lamps to program 1 (blue) & full brightness

## MODE 2: ON/OFF CONTROL

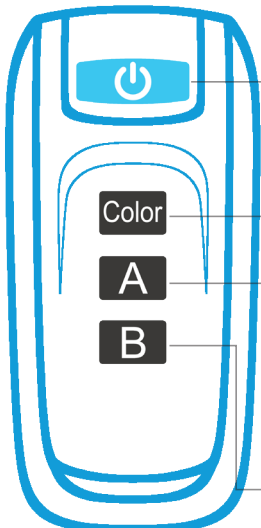

**Short push (< 1 sec):**

Toggle the lamp ON of OFF <sup>(1)</sup>

**Long push (> 2 sec<sup>(2)</sup>):**

All lamps & "12VAC TO LAMPS" relay are turned OFF <sup>(1)</sup>

**Short push:**

Go to next color program

**Long push:**

Auto sync procedure <sup>(3)</sup>

**Short push:**

Toggle output A ON/OFF

**Long push:**

/

**Short push:**

Toggle output B ON/OFF

**Long push:**

/

(1) Lamp ON or OFF status is memorized after power down

(2) The green LED in the transmitter will light up as soon as you start pressing a button, and will stop after 2 seconds, so you know exactly when to release the button.

(3) The lamps will be turned off for 30 seconds and then switched ON/OFF 3 times. This will set all lamps to program 1: blue

## Replacing transmitter Keypad (Control mode selection)

Depending on which control mode is selected, the keypad of the transmitter needs to be changed:

- Remove the philips head screw and open the transmitter
- Replace the Keypad in the top part of the transmitter housing
- Reassemble in reverse order

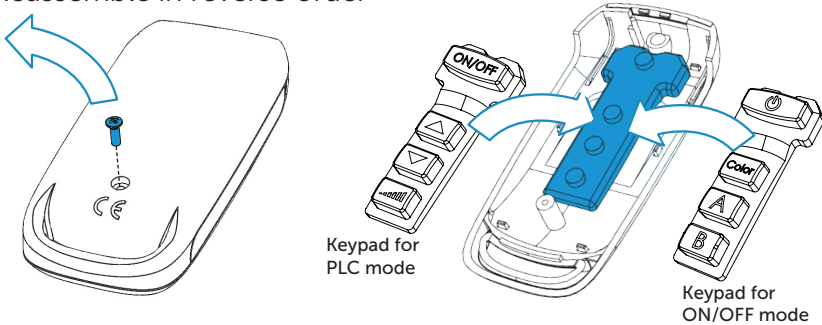

## Pairing the handheld transmitter to the PLP-REM controller

All handheld transmitters are already paired in the factory and ready to use. In case a problem arises, the pairing process can be done as below:

1) Press the pairing button on the small circuit board, inside the PLP-REM for at least 5 seconds

---> The GREEN LED will start to blink fast

2) Within 25 seconds, push any button on the handheld transmitter.

---> If the remote is paired correctly, the GREEN LED will flash slowly for 5 times

---> **UNPAIRING:**

If no button is pushed within 25 seconds, the pairing memory of the PLP-REM will be cleared. All remotes will be unpaired from the PLP-REM (in this "unpaired" mode, the PLP-REM will communicate with ANY transmitter)

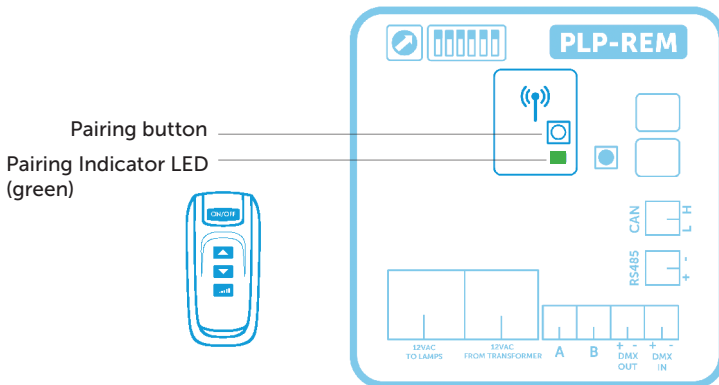

# DMX 512 communication

## Single PLP-REM unit

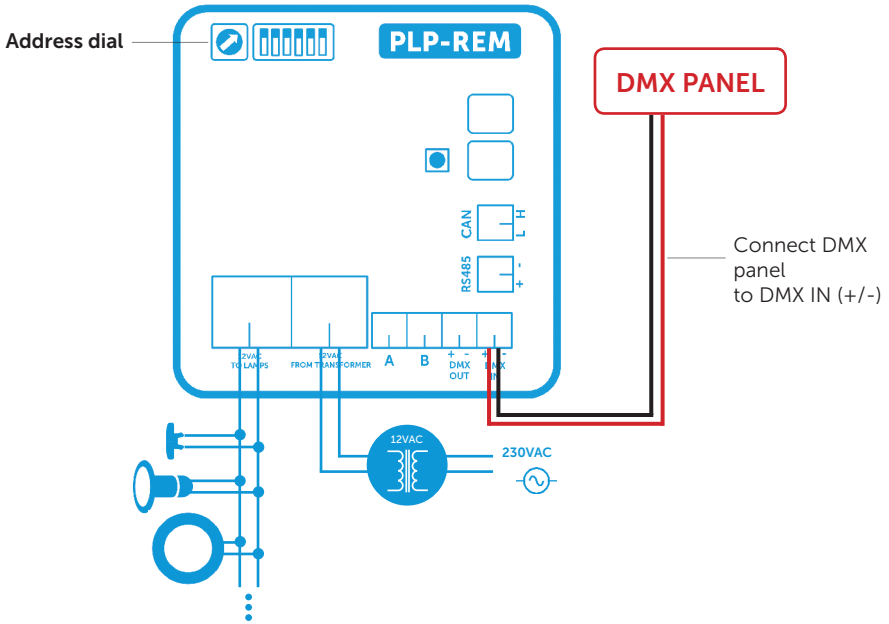

## Address dial setup

Setting the DMX address of the PLP-REM:

Select the desired number on the address dial. The chosen number determines the DMX addresses of the PLP-REM & lamps.

Each lamp uses 3 bytes of DMX data (R-G-B), and all lamps receive the same DMX data from the PLP-REM.

Address dial position	0			1			2			...
	R	G	B	R	G	B	R	G	B	...
DMX address	1	2	3	4	5	6	7	8	9	...

The DMX start address can be overruled by using the RS-485 command: "set DMX start address" (see page 16)

## Multiple PLP-REM installation

- 1) Connect the DMX panel to the "DMX IN" port of the first PLP-REM
- 2) Connect the PLP-REM's with each other (open loop):  
DMX OUT --> DMX IN (polarized terminals + -)
- 3) Set the DMX address for each PLP-REM via the address dial.
  - Option 1: All PLP-REM's can be set to the same address:  
This implies that all lamps will receive the same DMX data,  
And will all operate identically
  - Option 2: PLP-REM's can be set to different addresses:  
Each PLP-REM will have it's own group of connected lamps  
that will operate identically.  
However, since each PLP-REM has it's own unique address,  
the different lamp groups can be controlled separately

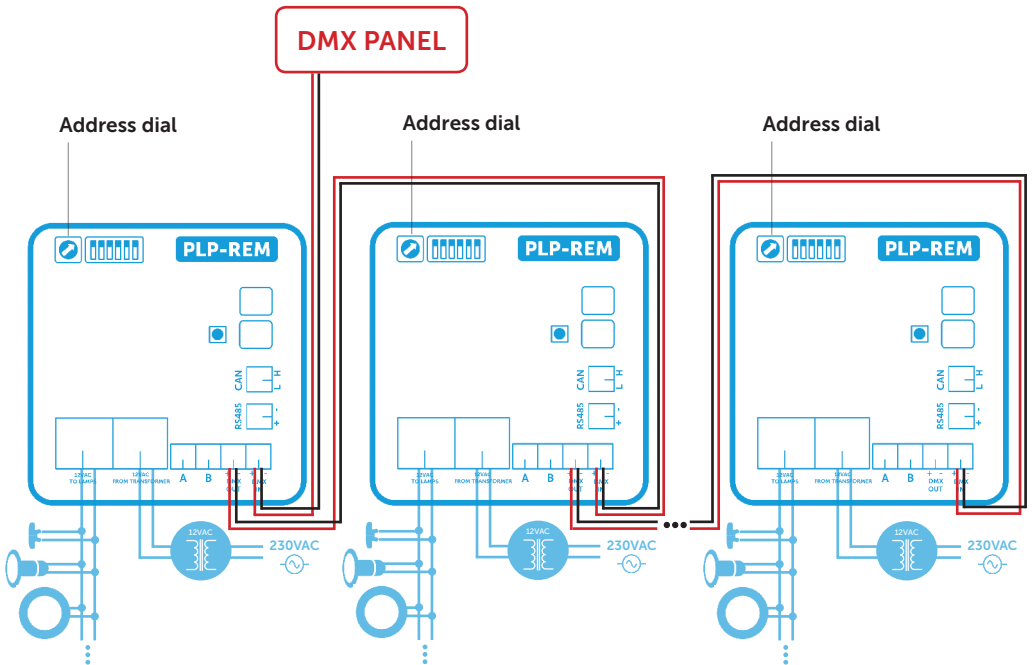

**Spectra**vision™  
lighting

# RS485 communication

## Single PLP-REM unit

- 1) Connect the RS485 source to the "485" port on the PLP-REM
- 2) Communication settings: 9600, 8, 1, n
- 3) Command list: see page 16

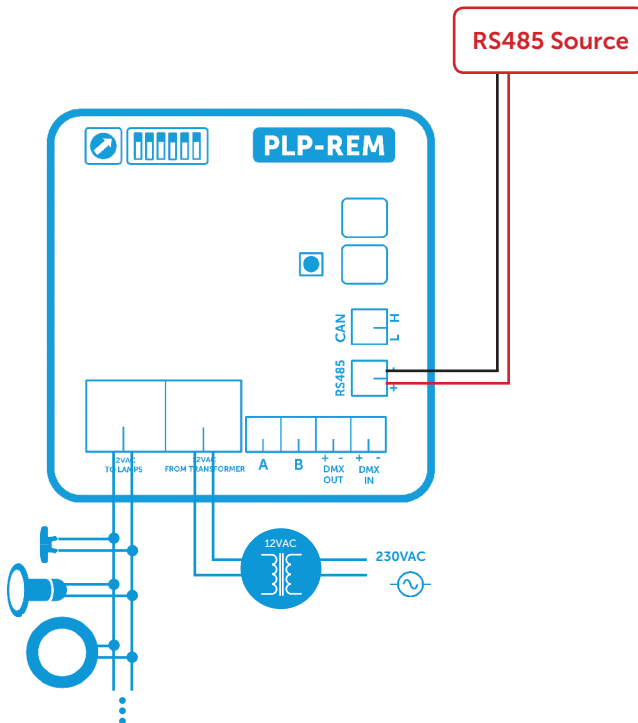

## Multiple PLP-REM installation

- 1) Connect the RS485 panel to the "RS-485" port of the first PLP-REM
- 2) Connect the PLP-REM's with each other in PARALLEL:  
Connect the CAN terminals of the first PLP-REM with the CAN terminal of the second PLP-REM. If more than 2 PLP-REM's are necessary, simply daisy chain each CAN terminal with the one from the next PLP-REM. Respect the polarity of the terminals! (CAN H & L)

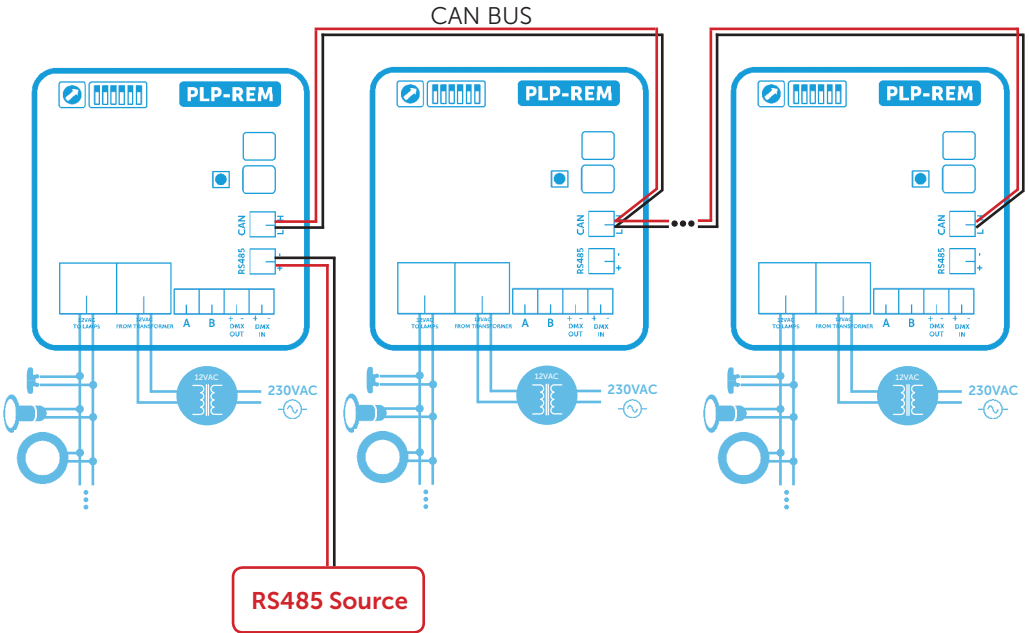

# RS485 Command set

Command	Command	Remark	Example	available in ON/OFF mode	available in P.L.C mode
Lamps OFF	PL0	All lamps OFF		X	X
Lamps ON	PL1	All lamps ON		X	X
Program Up	PsU	Jump to next program		X	X
Program Down	PsD	Return to previous program			X
Set Program	PSxx	xx is the decimal representation of the program number (01 - 14)	PS06 = jump to program 6		X
Auto sync procedure	PS	executes the auto sync procedure (see page 10)		X	X
White 1	PW1	Jump to White 1 (program 12)			X
White 2	PW2	Jump to White 2 (program 13)			X
White 3	PW3	Jump to White 3 (program 14)			X
Set RGB	PCrrrgggbbb	rrr, ggg and bbb are the decimal representation of the RGB value (with leading zero's)	1) PC255128064 = Full output level on Red color, half output level on Green color, 1/4 output level on Blue color 2) PC25525255 = All colors at full output level 3) PC00000000 = All colors OFF		X
Set Dim value	PDxxx	set the OUTPUT value of the lamp in % (000 - 100)	PD075 = 75% output level (on all LED's)		X
set DMX startAddress	PAxxxxyz	y = 'e' or 'E'	PA035E = set DMX start address to 35 [35(R), 36(G), 37(B)]		X
Set color in percentage	Pprgbe	variable size, rgb = ASCII 0-255, e = end character	Pp25050100e = Red 25%, Green 50%, Blue 100%		X
Set color in hex	Pcrgbe	variable size, rgb = ASCII 0-255, e = end character	Pc64128255e = Red 25%, Green 50%, Blue 100%		X
Relay A control	PRAx	x = 1 (ON), 0 (OFF), P (Pulse) !this overrides dipswitch	PRA1 = Relay A ON PRA0 = Relay A OFF	X	X
Relay B control	PRBx	x = 1 (ON), 0 (OFF), P (Pulse) !this overrides dipswitch	PRB1 = Relay B ON PRB0 = Relay B OFF	X	X
ON/OFF relay control	PRMx	x = 1 (ON), 0 (OFF)	PRM1 = Relay ON/OFF control ON	X	X
Color temperature	PTxyz	x = ten thousand ; y = thousand ; z = hundred	PT035 = Set white color temperature to 3500K (in steps of 500K)		X



# RESET procedure

## RESET procedure for the control board

- 1) Make sure the PLP-REM is switched ON
- 2) Press and hold the RESET button on the logic board for minimum 5 seconds. (the blue LED will light up as soon as you press, and will stop after 5 secs, so you know exactly when to release the button)
- 3) Release the RESET button

*The control board has been RESET.*

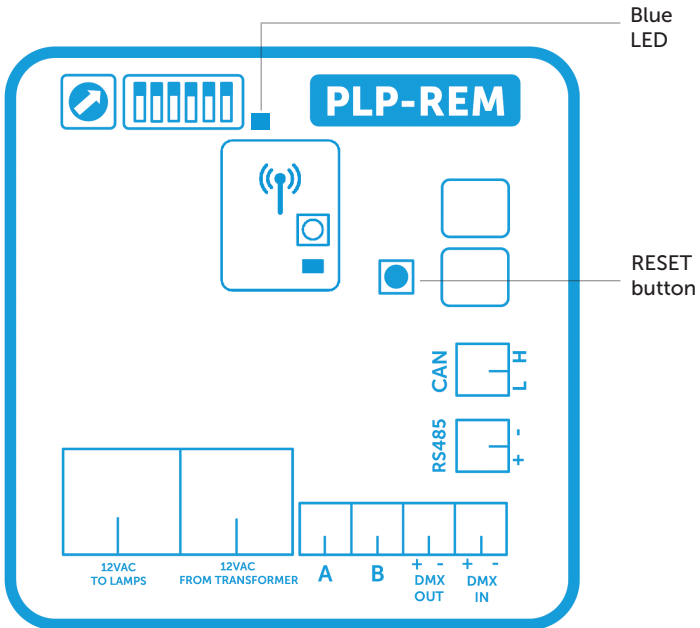

## Troubleshooting

### PROBLEM

The PLP-REM doesn't react to transmitter commands

### SOLUTION

- Perform a RESET procedure
- Check the battery of the handheld transmitter (see below)
- The transmitter is not paired-correctly with the PLP-REM. Repeat the pairing process
- Reduce the distance between handheld transmitter and PLP-REM and/or remove obstacles
- Check the General status light on the logic board. If it's red, then the secondary voltage is too high (>14VAC) or there is a short circuit

The pool lights don't work or don't change colors correctly

- Perform a RESET procedure
- Check if all connections are made according to the electrical scheme.
- Switch the PLP-REM to ON/OFF mode (DIP switch nr 1) and check if the lamps work

## Transmitter battery

*Check battery status:*

Push and release any button on the remote. The green LED should still light up 1 second after you released. If the LED stops faster, then the battery needs to be replaced

*Replacing transmitter battery:*

- Remove the philips head screw and open the transmitter
- Replace the battery, respecting the polarity

*Battery type: A23 12V*

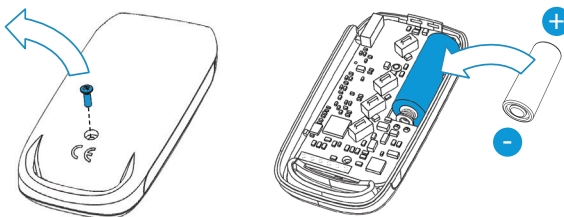

# Declaration of Conformity

We, Propulsion Systems bvba, declare under our sole responsibility, that the equipment described below conforms with the essential requirements of the following directives and standards:

**DIRECTIVE 2011/65/EC** (RoHS 2)

- EN 50581

**DIRECTIVE 1999/5/EC** Radio equipment and telecommunications terminal equipment and the mutual recognition of their conformity

- EN 300 220 Electromagnetic compatibility and Radio spectrum Matters (ERM); Short Range Devices (SRD); Radio equipment to be used in the 25 Mhz to 1000 Mhz frequency range with power levels ranging up to 500 mW

**DIRECTIVE 2006/95/EC (LVD)** Low Voltage Directive

- EN 61347-1 Control gear safety
- EN 61347-2-13 Control gear for LED modules

**DIRECTIVE 2004/108/EC** Electromagnetic compatibility

- EN 300 683 Electromagnetic compatibility and Radio spectrum Matters (ERM); Electromagnetic Compatibility (EMC) standard for Short Range Devices (SRD) operating on frequencies between 9 kHz and 25 GHz
- EN 301 489-3 Electromagnetic compatibility and Radio spectrum Matters (ERM); Electromagnetic Compatibility (EMC) standard for radio equipment and services, Part 3: Specific conditions for Short-Range Devices (SRD) operating on frequencies between 9 kHz and 40 GHz
- EN 55015:2009 EMC radio disturbance
- EN 61000-3-2:2009 EMC harmonic current
- EN 61547:2009 EMC immunity requirements

**Equipment:** handheld transmitter/receiver for remote control & base unit transmitter/receiver 868MHz band DuraLink™

**Trade Mark:** SpectraVision™

**Model Nr.:**      **Description:**

<b>PLA-REM</b>	Communications & remote control box for Adagio+ RGB DuraLink™
<b>PLA-REM-300</b>	350VA PSU & comms box for Adagio+ RGB DuraLink™
<b>PL-REM</b>	Remote control for Moonlight, Adagio+, Adagio Pro DuraLink™
<b>PL-REM-P</b>	Remote control for Moonlight, Adagio+, Adagio Pro (Pulsed) DuraLink™
<b>PL-REM-200</b>	200VA PSU & remote control for Moonlight, Adagio+, Adagio Pro DuraLink™
<b>PLP-REM</b>	Communications & remote control box for Spectravision lamps Duralink™
<b>PLP-REM-300</b>	350VA PSU & comms box for Spectravision lamps Duralink™
<b>TX868-PLA</b>	Transmitter; Duralink™ 868 MHz; for PLA-REM(-300)
<b>TX868-PL</b>	Transmitter; Duralink™ 868 MHz; for PL-REM(-60/200)

**Propulsion Systems bvba**

Dooren 72  
B-1784 Belgium

Date of signature: 12/01/2016

Signature:

Name: Mr. Marc Lamberts  
Title: Managing Director



# Pool light wiring instructions

## Adagio<sup>PRO</sup>

Each lamp is connected to the transformer by a separate cable (Preferred for new installations)

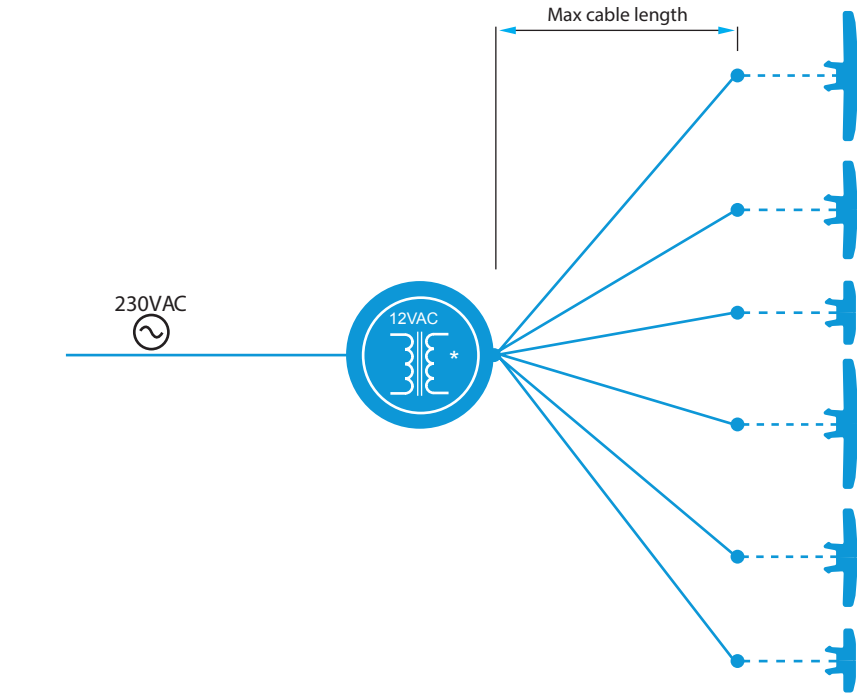

- - - - 4m cable included in lamp package

———— Separate cable ( not included )

 **Warning:** Always use a Torroidal transformer

## MAX CABLE LENGTH BY CABLE CROSS SECTION

LAMP TYPE	1,5 mm <sup>2</sup>	2,5 mm <sup>2</sup>	4,0 mm <sup>2</sup>	6,0mm <sup>2</sup>	10mm <sup>2</sup>	VA TRANSFORMER (12VAC)*
PLP050-WH PLP050-WW PLP050- BL	77m	129m	207m	311m	519m	16
PLP100-WH PLP100-WW PLP100-BL	21m	35m	57m	85m	142m	56
PLP170-WH (-LC) PLP170-WW (-LC) PLP170-BL	4m	7m	11m	16m	28m	147
PLP50-RGB	62m	103m	165m	248m	414m	12
PLP100-RGB	12m	20m	33m	50m	80m	48
PLP170-RGB (-LC)	6m	10m	16m	25m	42m	82

**MAXIMUM AND STABLE LIGHT OUTPUT IS ONLY GUARANTEED WHEN THE INSTALLED CABLE CROSS SECTION MATCHES OR EXCEEDS THE ADVISED VALUES IN THE ABOVE TABLE**

\* The transformer VA rating must be greater or equal to the sum of VA ratings of all connected lamps.

These cable lengths are calculated with worst case voltage drops in the electrical wiring.





## Contact details

### Propulsion Systems bvba

Dooren 72  
1785 Merchtem, Belgium

Tel +32 2 461 02 53

Fax +32 2 706 59 60

[www.propulsionsystems.be](http://www.propulsionsystems.be)

[info@propulsionsystems.be](mailto:info@propulsionsystems.be)



**Spectra**vision<sup>TM</sup>  
lighting

