



GUIDE FOR INSTALLATION OF MP REACTORS



GENERAL

ENVIRONMENT FOR USE

Place	In a compartment protected from freezing and from the rain
Maximum ambient T°	+ 40°C
Minimum ambient T°	+ 5°C
Maximum relative humidity	80%

PRESENCE OF CHEMICAL PRODUCTS

- The technical compartment must be well ventilated.
- Place the UV reactor as far away as possible from sources of acid or chlorine
(Cartridges connected to the regulation systems or stock,, buffer tank, etc)

POSITION OF THE UV REACTOR IN THE SYSTEM

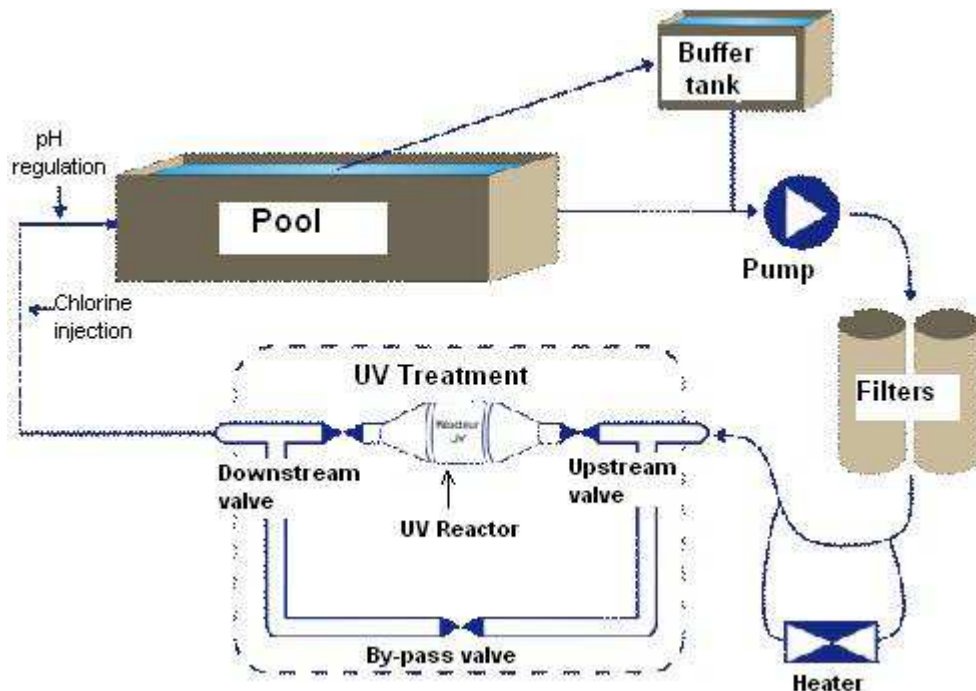

Injection of water treatment products must be performed upstream from the UV reactor.

Observe a minimum distance of 2m between the UV reactor and the chlorine injection

In compliance with the regulations, the injection of treatment products must be performed as close as possible to the pool.

HYDRAULIC INSTALLATION

1. INSTALL THE UV REACTOR: A BY-PASS WILL FACILITATE MAINTENANCE OPERATIONS

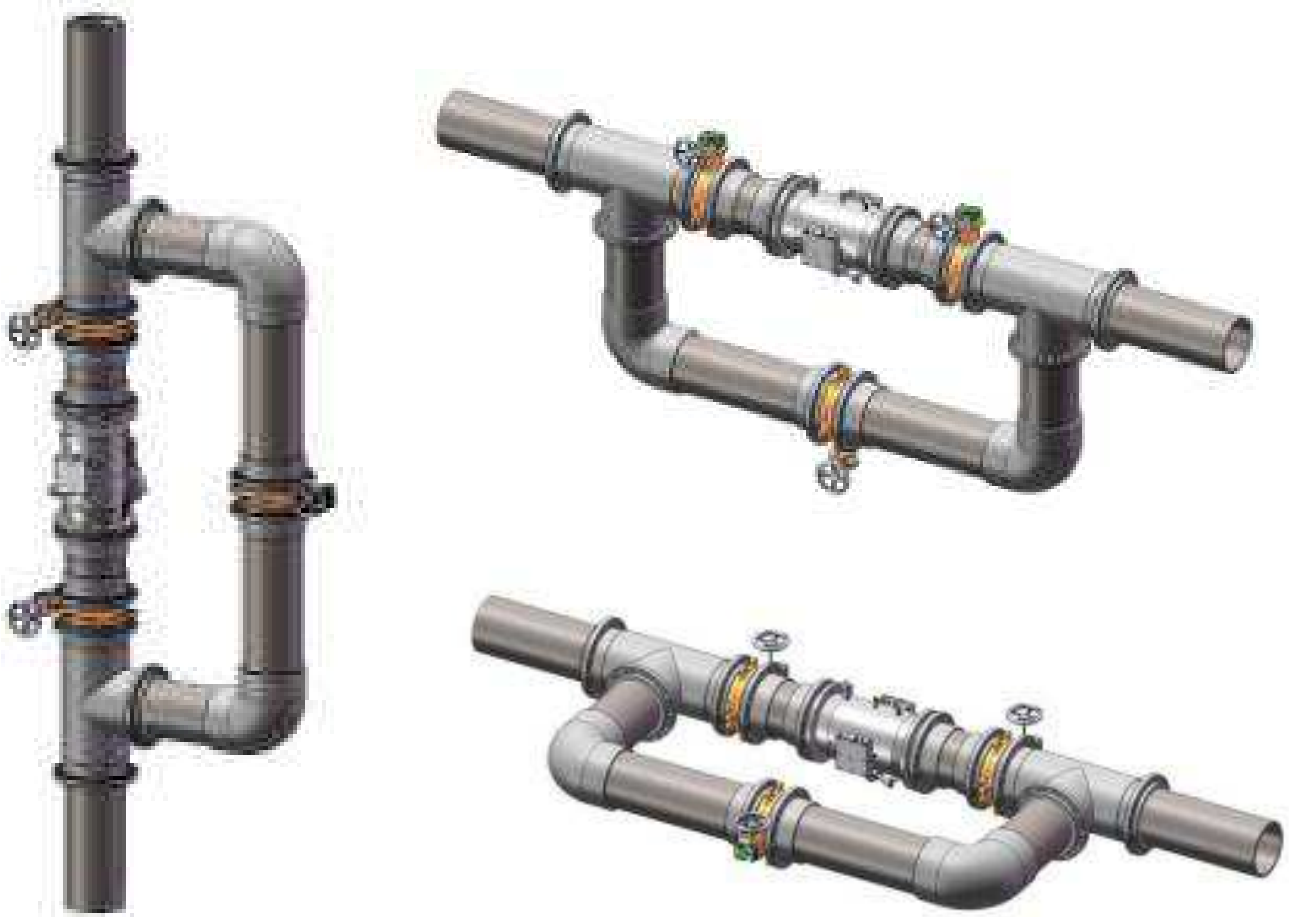

- The UV reactor must always be full
- The pipe diameter should preferably be the same as the diameter of the UV reactor's input/output.
- Do not install cut-off valves directly on the UV reactor.

- The cut-off valves upstream and downstream from the UV reactor must be close to it to facilitate the draining of the reactor for maintenance operations: 50 cm recommended

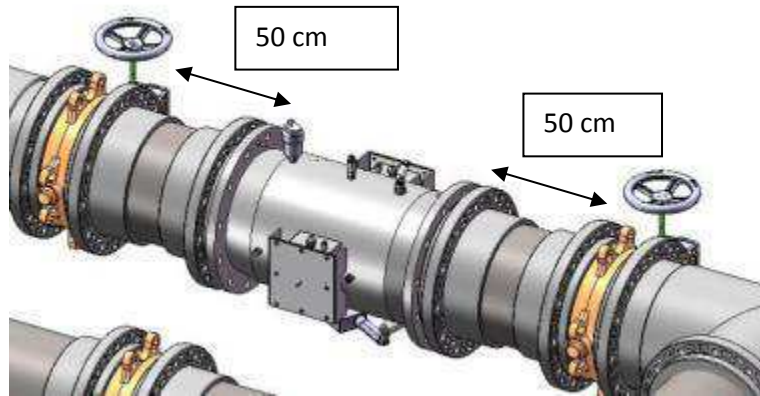

2. IF AN ELBOW IS PRESENT UPSTREAM FROM THE REACTOR: IF POSSIBLE PROVIDE A LENGTH OF STRAIGHT PIPE EQUAL TO AT LEAST THREE TIMES THE NOMINAL DIAMETER DOWNSTREAM FROM THE ELBOW

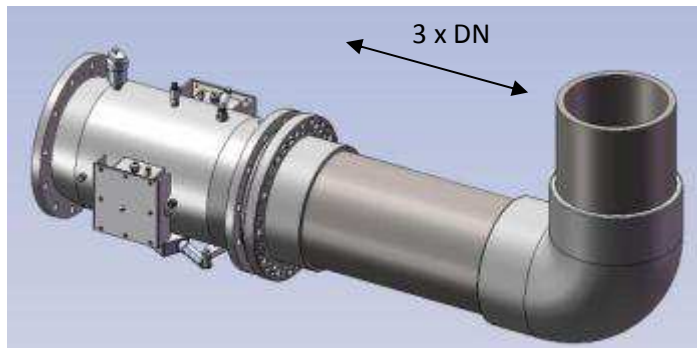

MODEL	STANDARD DN	RECOMMENDED LENGTH OF STRAIGHT PIPE IN MM
MP100 EL	DN 125	375 mm
MP125 EL	DN 150	450 mm
MP140 EL	DN 200	600 mm
MP240 EL	DN 250	750 mm
MP340 EL	DN 300	900 mm
MP440 EL	DN 300	900 mm

3. **IF A T-JUNCTION IS PRESENT UPSTREAM FROM THE REACTOR (For example, arrival of the heater by-pass): IF POSSIBLE PROVIDE A LENGTH OF STRAIGHT PIPE EQUAL TO AT LEAST THREE TIMES THE NOMINAL DIAMETER DOWNSTREAM FROM THE T-JUNCTION**

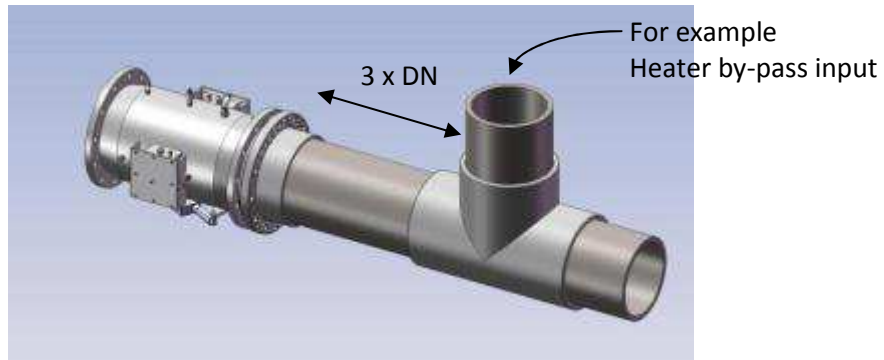

4. **IF A REDUCING PIECE IS PRESENT UPSTREAM FROM THE REACTOR: IF POSSIBLE PROVIDE A LENGTH OF STRAIGHT PIPE EQUAL TO AT LEAST THREE TIMES THE NOMINAL DIAMETER DOWNSTREAM FROM THE REDUCING PIECE**
5. **UPSTREAM AND DOWNSTREAM FROM THE UV REACTOR: USE LOOSE FLANGES IF POSSIBLE**

This will make it easier to place the UV lamps in the horizontal position.

6. HORIZONTAL MOUNTING OR VERTICAL MOUNTING: 2 solutions for greater flexibility

6.1 Horizontal mounting

- The UV lamps must be in a horizontal position.
- The UV sensor must be in the upper position, the cleaning handle (for the manual version) or the actuator (for the automatic version) must be located below the UV reactor.
- The reactor's main drain is therefore properly located underneath the reactor to drain it easily during maintenance

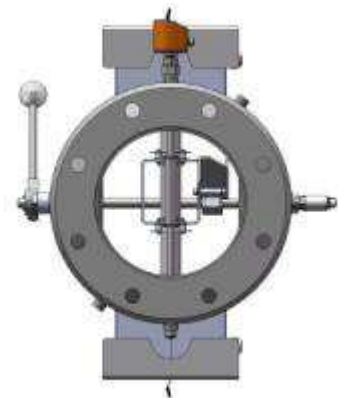

6.2 Vertical mounting: To ensure that the reactor is always full, it is best to have the water flowing in through the bottom of the reactor and out through the top.

- You must ensure that the drains are located in the lower position: If the direction of water flow is observed, then they will be correctly positioned.



Vertical mounting: if there is no other installation possibility and the water input is through the top of the reactor, make sure that the assembly is such that it allows the UV reactor to be completely full.

7. OBSERVE THE DIRECTION OF WATER FLOW, SYMBOLISED BY THE ARROW AND THE WORD "FLOW" ON THE REACTOR

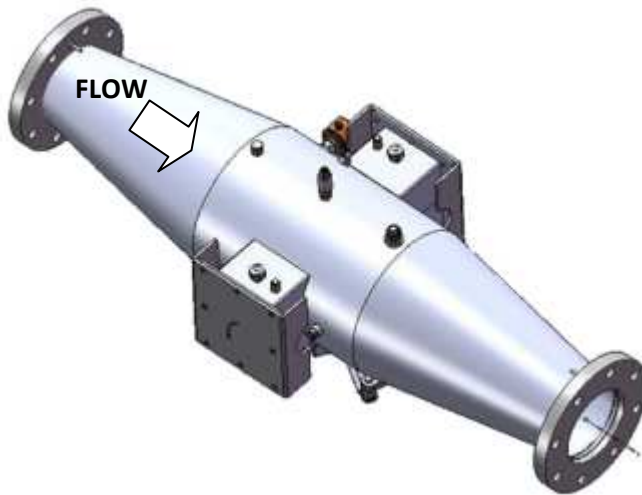

8. FOR MAINTENANCE: ENSURE THERE IS ENOUGH FREE SPACE AROUND THE REACTOR

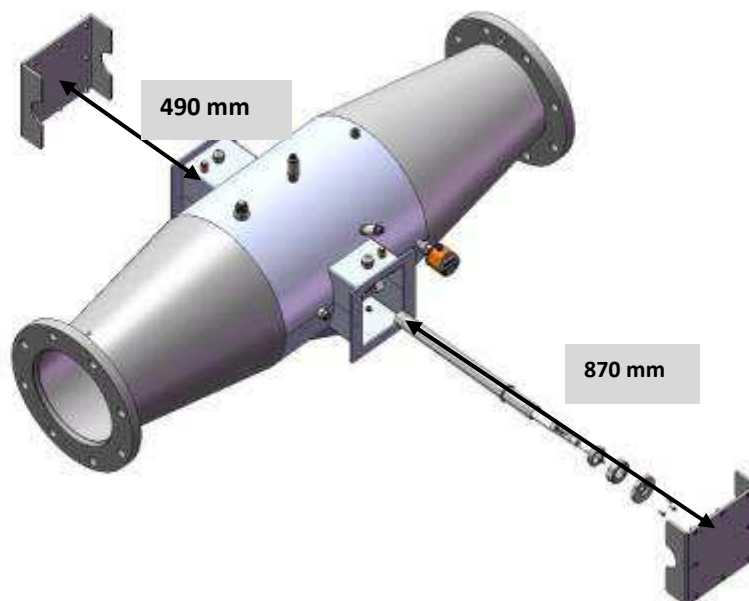

10. IN CASE OF RISK OF MICROBUBBLES: TO AVOID HAVING TO DRAIN THE REACTOR REGULARLY, INSTALL AN AUTOMATIC DRAIN.

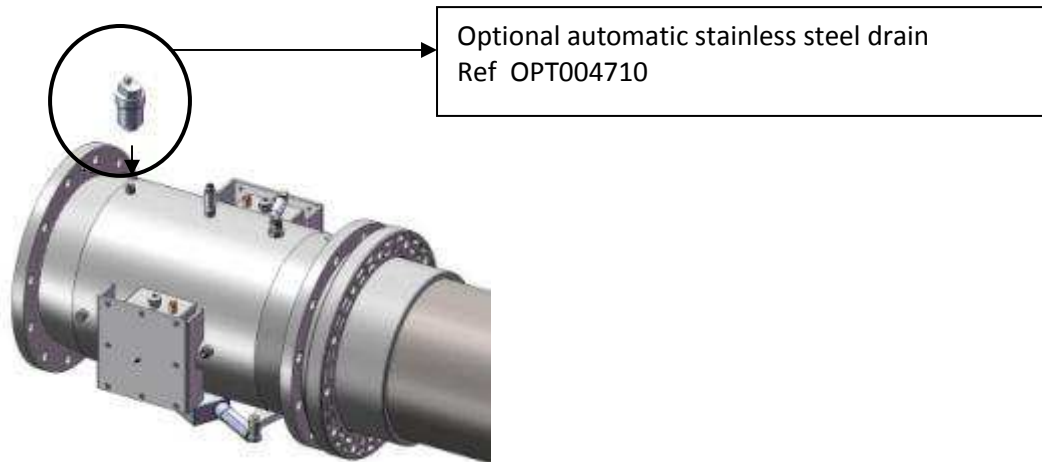

11. TO PROTECT THE POOL IN THE EVENT OF BREAKAGE OF THE QUARTZ SLEEVE, INSTALL A STRAINER ON THE UV REACTOR'S OUTPUT FLANGE

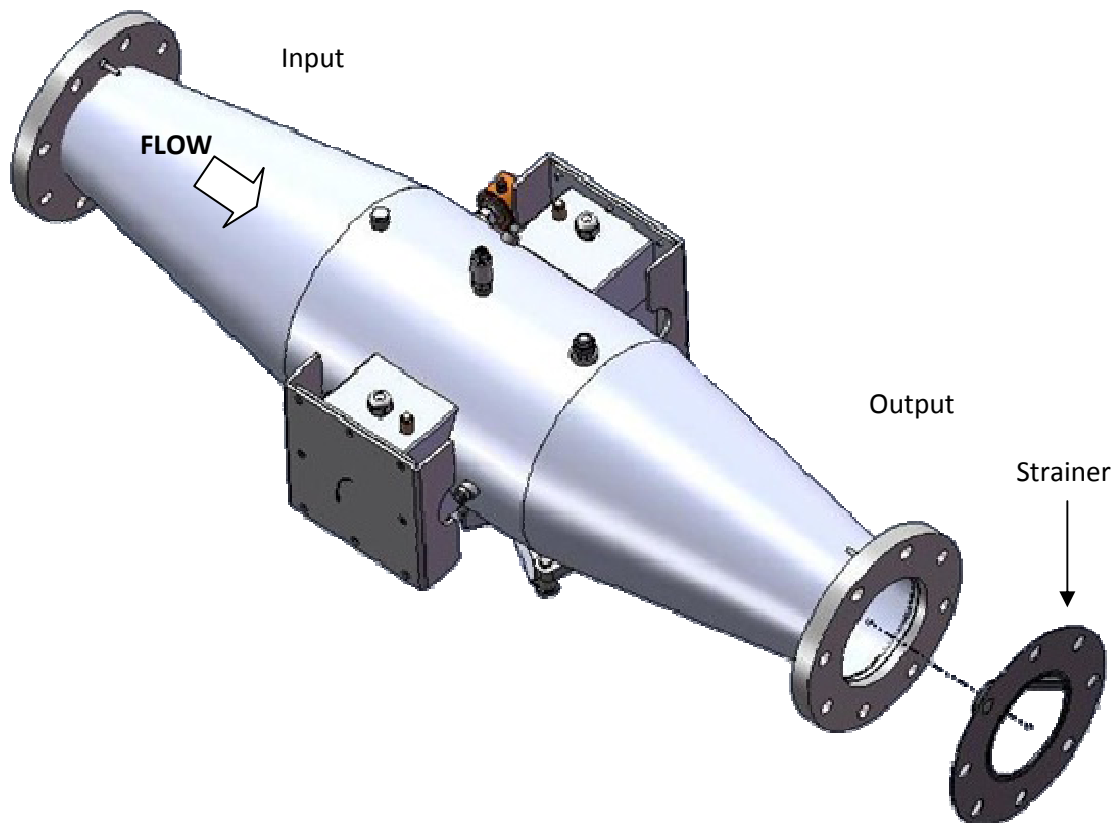

ELECTRICAL INSTALLATION

1. FIX THE CABINET TO THE WALL, OBSERVING THE CLEARANCES AROUND THE VENTILATION GRILLS

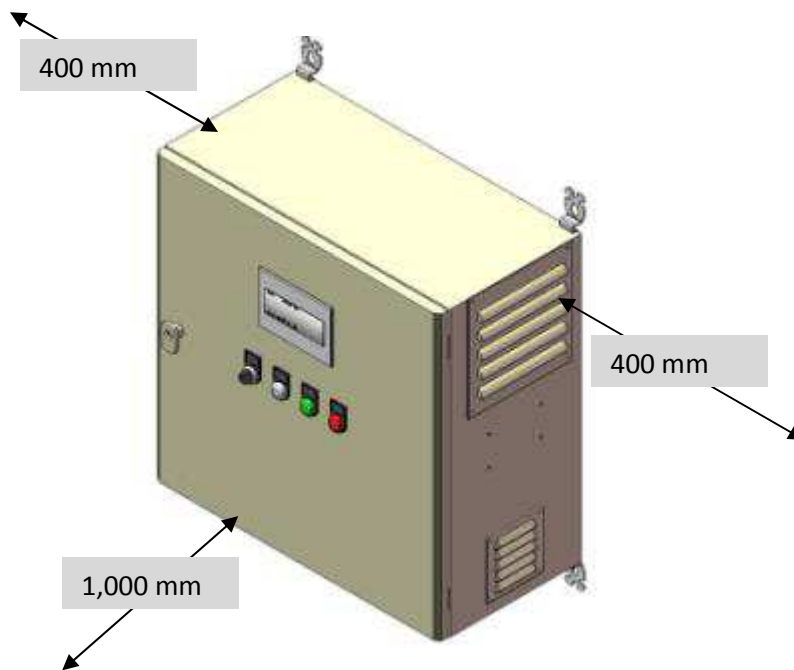

SIZE OF THE ELECTRICAL CABINETS

UV REACTOR	SIZE OF THE CABINET	WEIGHT
MP100	600x600x300 mm	44 kg
MP125	600x600x300 mm	48 kg
MP140	600x600x300 mm	57 kg
MP240	600x600x400 mm	61 kg
MP340	800x600x400 mm	67 kg
MP440	1,000x800x400 mm	72 kg

2. THE REACTOR MUST BE CONNECTED TO EARTH

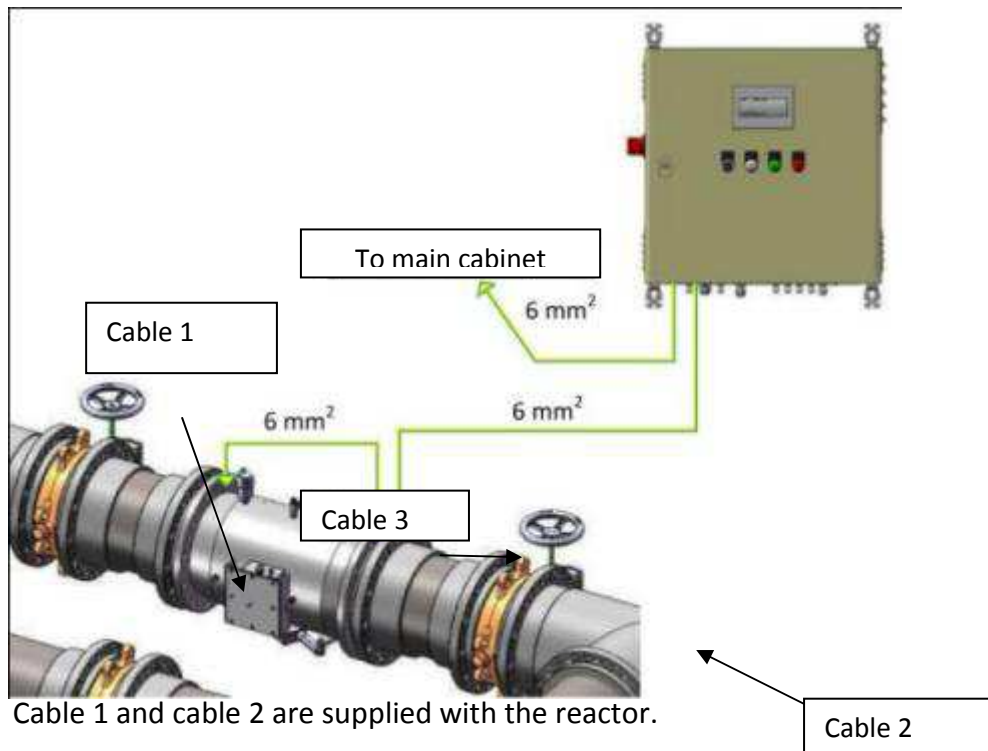

Any reactor earthing fault will entail a guarantee exclusion in the event of electrolytic corrosion.

3. THE UV REACTOR MUST BE CONNECTED AND PROTECTED ON THE MAIN SWITCHBOARD BY A SUITABLY RATED CIRCUIT BREAKER

The electrical cabinet must be connected directly to the low voltage main switchboard. It must not be slaved to the filtration, its operation is independent and controlled by a flow sensor.

A protective device reserved for the UV reactor must be provided in the low voltage main switchboard.

MODEL	POWER CONSUMED	PROTECTION OF THE UV REACTOR	MINIMUM SUITABLE PROTECTION*
MP100 EL	1,100 W	2 poles, 10 A curve C	≥ 2 poles, 10 A curve C
MP125 EL	3,300 W	2 poles, 25 A curve C	≥ 2 poles, 25 A curve C
MP140 EL	3,300 W	2 poles, 25 A curve C	≥ 2 poles, 25 A curve C
MP240 EL	6,600 W	3 poles, 25 A curve C	≥ 3 poles, 25 A curve C
MP340 EL	9,900 W	4 poles, 25 A curve C	≥ 4 poles, 25 A curve C
MP440 EL	13,200 W	4 poles, 40 A curve C	≥ 4 poles, 40 A curve C

*in accordance with the NF C15-100 standard

4. LAMP AND SENSOR CABLES

10m long, they must be unwound to prevent any loops.

GUARANTEES

The terms of guarantee for the equipment in the BIO-UV range are as follows:

- **5 years** for the stainless steel reactor (materials and welds) except when used in a very corrosive environment or atmosphere (brackish or very salty water, sea water, near to acid and corrosive products, use of hydrochloric acid).

Exclusions:

Exceptional cases of corrosion, particularly electrolytic.

Damaged caused by over pressure (pressure surges)

Overshooting of the Maximum Working Pressure

Non-compliance with the installation instructions

Reactor having been operated without being full

- **2 years** for all components with the exception of the UV lamp (consumable).

Exclusions:

The consumable items (gaskets, scrapers)

The electrical components are not guaranteed against overvoltage or lightning strikes.

Modification and addition of components in the electrical cabinets

Use of spare parts that do not originate from BIO-UV

Non-compliance with the installation instructions

Reactor having been operated without being full

Non-compliance with the operating and maintenance instructions.



Note: the quartz sleeve and the lamp are not guaranteed against breakage.

- **Faulty parts must be sent back** to BIO-UV with details of the **type** and the **equipment serial number**. BIO-UV will replace them after carrying out a technical survey.
- **The cost of shipping will be shared** between the retailer and BIO-UV.
- **The guarantee** takes effect on the day of the installation of the equipment: this date must be communicated to BIO-UV by sending the guarantee validation by post or by fax.

- If the installation rules and instructions for use **are not complied with**, BIO-UV cannot be held liable and the guarantee cannot be invoked.

Installation instructions		Y	N
no.1	We recommend installing the reactor in line and having a by-pass and cut-off valves nearby for maintenance		
no.2	The MP cabinet MUST be connected directly to the mains, slaving in the event of the pump(s) stopping will be provided by the flow meter integrated into the reactor		
no.3	We recommend that the reactor input is at least 50 cm away from the first elbow		
no.4	Chlorine and pH- injections MUST be after the UV		
no.5	The UV lamp MUST be perfectly HORIZONTAL, whatever the position of the reactor.		
no.6	The reactor and cabinet MUST be correctly connected to the main earth of the building by an earth wire with a cross-section of at least 6 mm ² .		
no.7	Essential: Make sure you observe the instructions for the space around the lamps and quartz sleeves.		
no.8	When the UV reactor is horizontal, we recommend that the UV sensor is in the upper position, and the cleaning handle underneath the reactor.		
no.9	If the UV reactor is installed vertically, the water input MUST be via the bottom of the reactor and the drains MUST be in the lower position.		
no.10	Essential: Do not create loops with the lamp cables		
no.11	The cabinet air inputs/outputs MUST be clear.		
no.12	For 140 EL MPs, you MUST observe the direction of water flow, symbolised by the arrow and the "FLOW" inscription on the reactor.		
no.13	Essential: keep chemical products away from the reactor to prevent any risk of corrosion. The compartment must be well ventilated		
no.14	<u>Strainer option (strainer filter):</u> it must be installed on the output of the UV cone on the UV side		
no.15	<u>Automatic stainless steel drain option:</u> (In horizontal position only) it must be installed on the ¼" upper drain plug branch		
no.16	<u>4-20mA option:</u> Connection to the CTM		
no.17	<u>Temperature probe option:</u> it must be screwed into the ¼" blind opening on the side		
no.18	<u>Automatic cleaning option:</u> The motor actuator must be underneath the reactor		

SHEET TO RETURN COMPLETED TO BIO-UV TO VALIDATE THE GUARANTEE	
Instructions checked and validated by:	
Company:	Signature(s):
Type of equipment:	Serial number
Site:	Established on: