

# User Manual

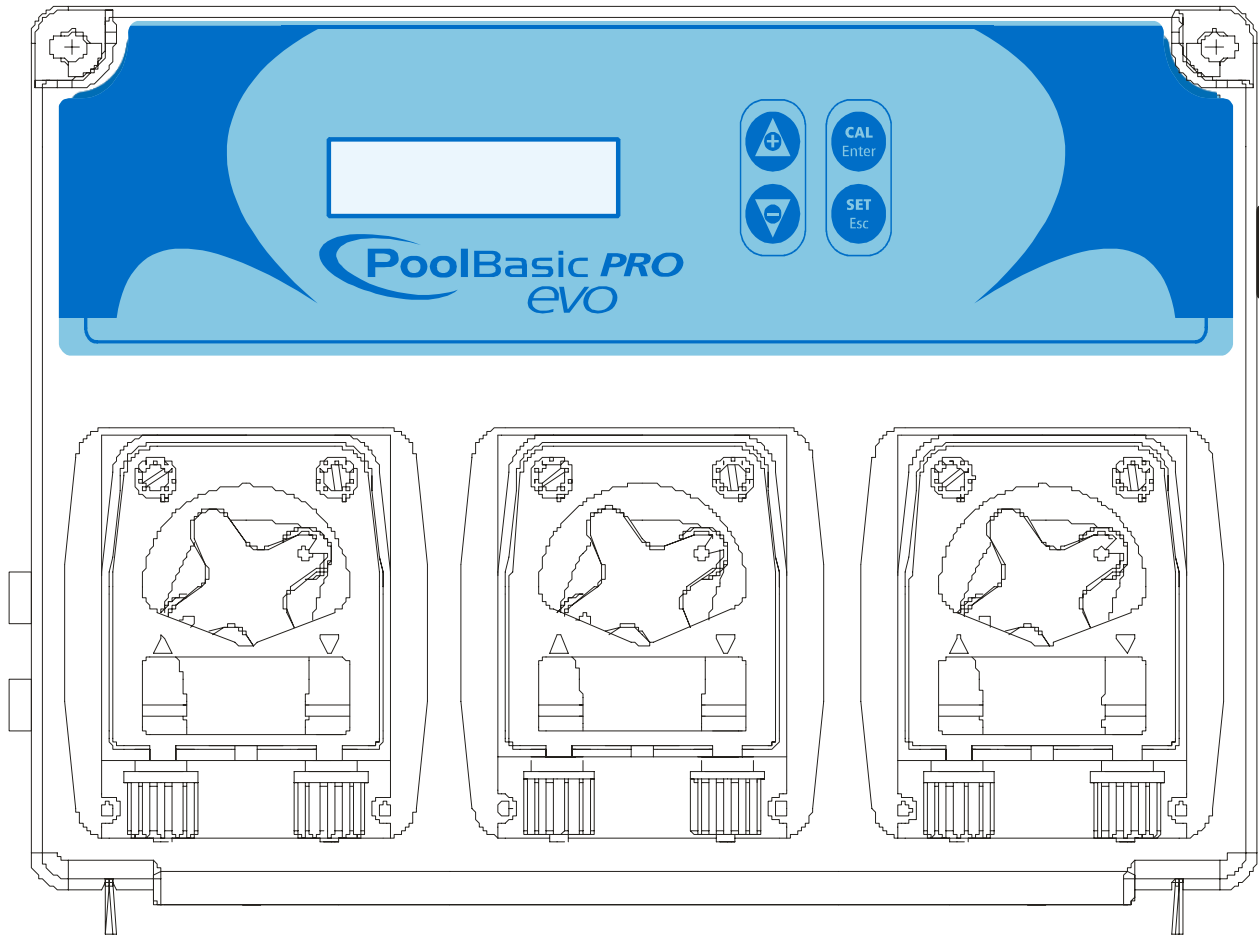

# CONTENTS

1. GENERAL INTRODUCTION
  2. INSTALLATION PRECAUTIONS
  3. IDENTIFICATION OF COMPONENTS
  4. TECHNICAL SPECIFICATIONS
  5. ASSEMBLY INSTRUCTIONS
    - 5.1 APPLICATION EXAMPLE
  6. DESCRIPTION OF THE CIRCUIT
  7. CALIBRATION MENU
    - 7.1 CALIBRATION
  8. PROGRAMMING
  9. DOSING METHOD
  10. ACTIVATIONS
  11. ALARMS
  12. PRE-DEFINED CONTROL PARAMETERS
  13. LIST OF POSSIBLE ANOMALIES AND RELATIVE SOLUTIONS
  14. HANDLING
  15. STORING THE PUMP AFTER USE
- WARNINGS

## 1. GENERAL INTRODUCTION

The **Pool Basic Pro EVO** control method belongs to a new line of instruments carefully developed by the supplier for the innovative management of pools. This device is easy to use and permits continuous control of the pH.

The peristaltic pumps have a 1,5 l/h flow rate for pH regulation and have a pressurised injection flow rate up to 1.5 bar.

This easy-to-use instrument does not require special maintenance operations. It is equipped with a self-regulation procedure and automatic control of the electrode's state.

## 2. INSTALLATION PRECAUTIONS

### WARNING!!!

**Disconnect power before carrying out ANY operation inside the control panel of the Pool Basic Pro EVO device.**

*NON-OBSERVANCE OF THE INSTRUCTIONS CONTAINED IN THE PRESENT MANUAL COULD CAUSE INJURY TO PEOPLE AND/OR DAMAGE TO THE DEVICE.*

### WARNING

During installation of the **Pool Basic Pro EVO** device, proceed as follows:

- Make sure that the supply voltage coincides with the one indicated on the label on the side of the device.
- Make sure that the injection pressure is below 1.5 bar.
- Make sure that the pump's protective cover is properly latched.
- Make sure that the suction hose is immersed with the relative foot (PVC hose) in the tank of the product which must be injected and that it is connected to the pump (symbol on cover ▲). After carrying out the checks stated above, tighten the connector nut.
- Connect one end of the delivery hose (▼ symbol on cover) to the pump and connect the other end to the pool through the injection valve.

**NOTE:** To insert the product which must be injected into the pump when starting for the first time and every time the tank is changed, set the switch to forced running using the button.

### 3. IDENTIFICATION OF COMPONENTS

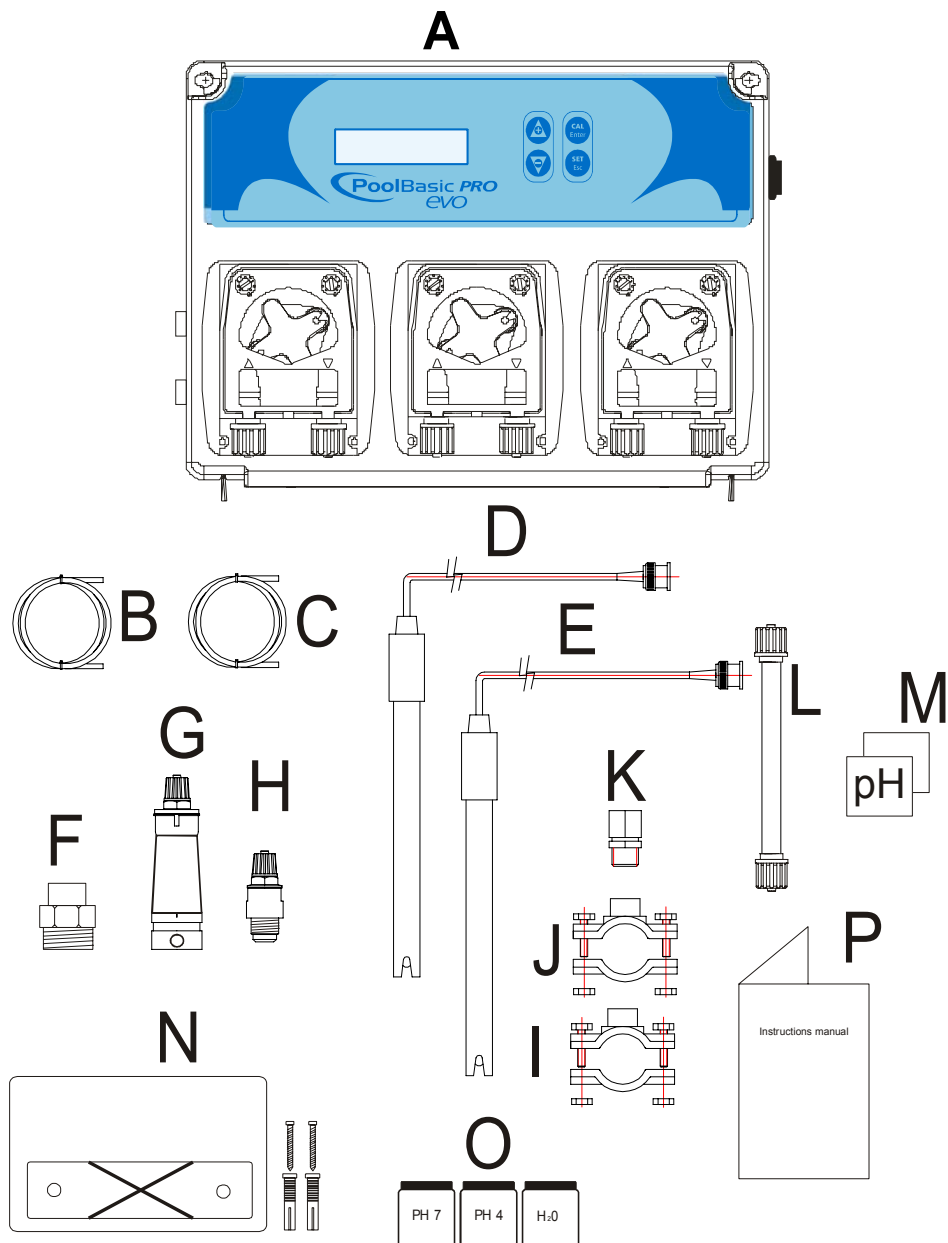

#### KEY

- A. **Pool Basic Pro EVO** regulator
- B. Suction hose in PVC Crystal 4x6 (4 m) x 2
- C. Delivery hose in PE 4X6 (5 m) x 2
- D. pH Electrode model SPH-1
- E. Redox Electrode
- F. Reducer for injection valve x 2
- G. Duckbill valve in FPM (3/8" GAS) x 2
- H. Suction foot (PVC hose) x 2
- I. Tapping double-bolt clamp for fastening PSS3 probe holder onto 2"  $\phi=50$ mm hose
- J. Tapping double-bolt clamp for fastening injection valve onto 2"  $\phi=50$ mm hose x 2
- K. Probe holder model PSS3 (1/2" GAS)
- L. Hose 3x7
- M. Labels to be stuck onto the pumps
- N. Fixing bracket kit
- O. pH 4, pH 7, H<sub>2</sub>O Buffer solution kit
- P. Instruction Manual

## 4. TECHNICAL SPECIFICATIONS

- **Power supply:** 100÷240 Vac 50/60 Hz 30 watt
- **Switch:** on side of box
- **Inlet measurements:** pH, through BNC
  - pH scale: 0÷14.0 pH
  - pH precision: +/-0.1 pH
  - Redox scale: 0÷1500mV
  - Redox precision: +/-10 mV
- **Temperature Scale:** 0÷100 °C (PT100 sensor)
- **Pump flow rate** with transaxle technology:
  - **pH, pH-, pH+:** 1.5 l/h (hose 6X10) 1.5 bar
  - **Flocculant:** 0.4 l/h (hose 3X7), 1.5 l/h (hose 6X10) 1.5 bar
- **Pump relay PH-, pH:** 10 A 250 V (dry contact)
- **Relay for alarm or Redox:** 10 A 250 V (dry contact)
- **Relay for PH+, Flocculant:** 10 A 250 V (dry contact)
- **Dedicated power for pumps:** 240 Vac 10 watt
- **Input signal:** 100÷240 Vac
- **Level probe:** pH, Redox, Flocculant

Install the **Pool Basic Pro EVO** control device on a hard support (vertical wall) where it can be easily accessed by the operator. Attach the **Pool Basic Pro EVO** control device using the provided fixing bracket (distance between centre of holes: 95mm. Hole Ø 6).

Before carrying out any operation inside the equipment, make sure that the switches are on 0. Unscrew the two screws on the upper part of the equipment by a quarter of a turn and the front side will fold down on the hinges.

## 5. ASSEMBLY INSTRUCTIONS

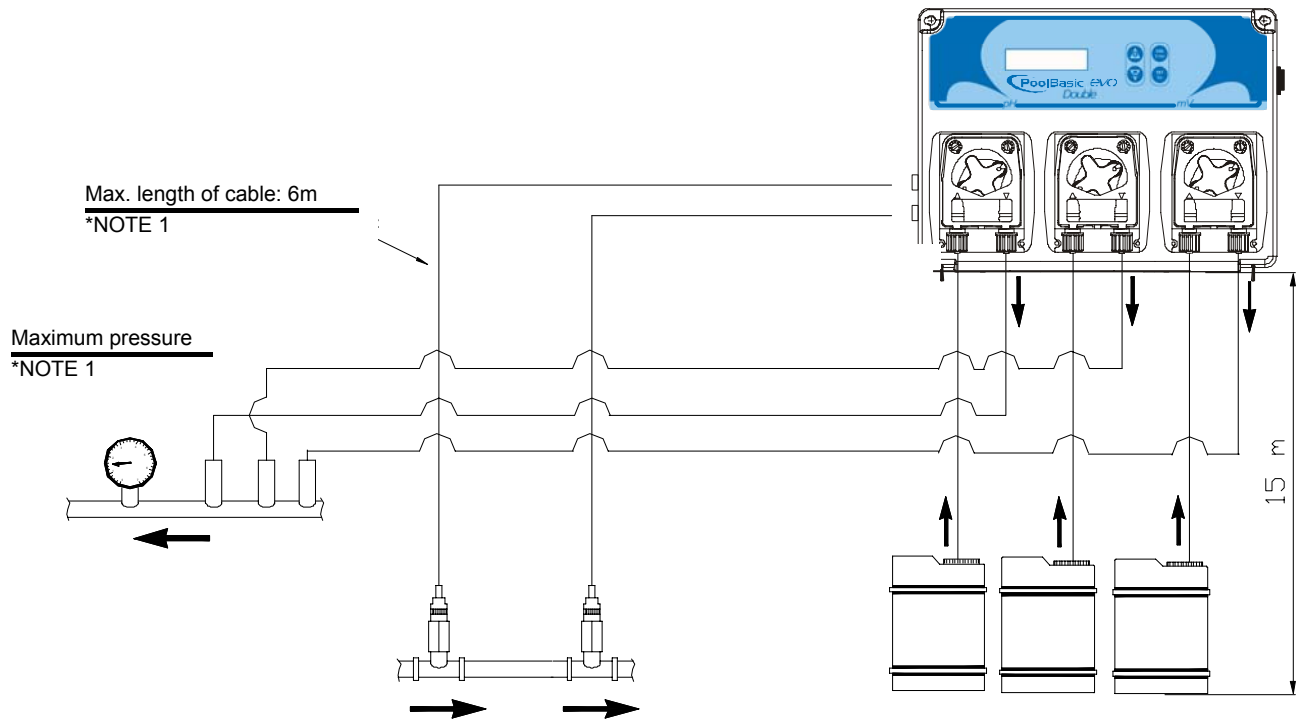

**\*NOTE 1: FOR LARGE PUMPS, THE CABLE MUST PASS THROUGH AN AREA OTHER THAN THE POWER SUPPLY ZONE IN ORDER TO PREVENT CURRENT DISTURBANCES.**

**\*NOTE 2: THE MAX. PRESSURE MUST NOT EXCEED 1.5 BAR.  
TO INCREASE THE HOSE'S LIFETIME, THE PRESSURE MUST NOT EXCEED 1 BAR.**

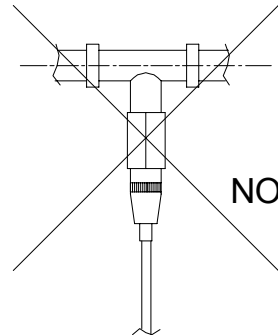
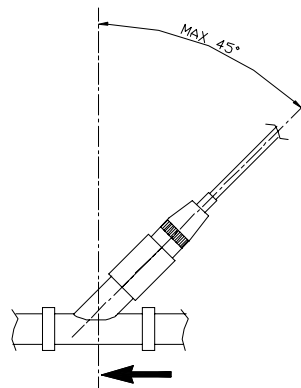
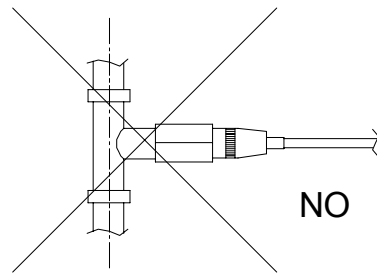
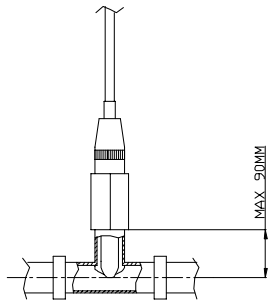

## 5.1 APPLICATION EXAMPLE

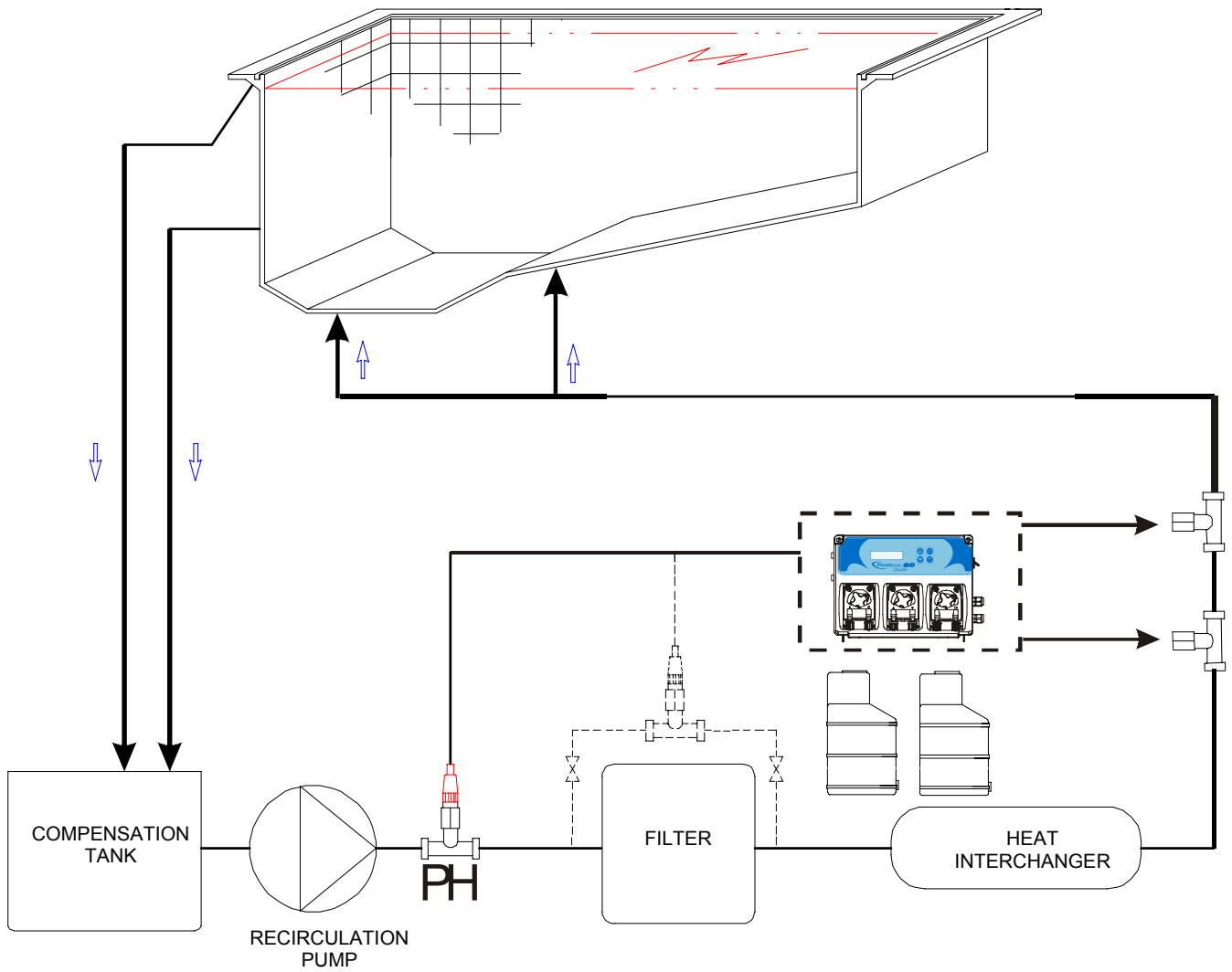

### Note:

The linear distance of the hose between the probe and the point of injection must not be less than 60cm.

## 6. DESCRIPTION OF THE CIRCUIT

- 1) Inlet pH measurement
- 2) Inlet Redox measurement
- 3) Inlet temperature probe
- 4) Inlet probe level for product pH-/Floc
- 5) Inlet probe level for product Redox
- 6) Inlet probe level for product pH+/pH
- 7) Keyboard input
- 8) Flow (recirculation pump)
- 9) Relay for pH-/pH product, external pump
- 10) Alarm relay or for Redox product, external pump
- 11) Relay for pH+/Floc product, external pump
- 12) Power supply input
- 13) Switch
- 14) Fuse
- 15) Power supply for pH-/pH pump
- 16) Power supply for Redox pump
- 17) Power supply for pH+/Floc pump

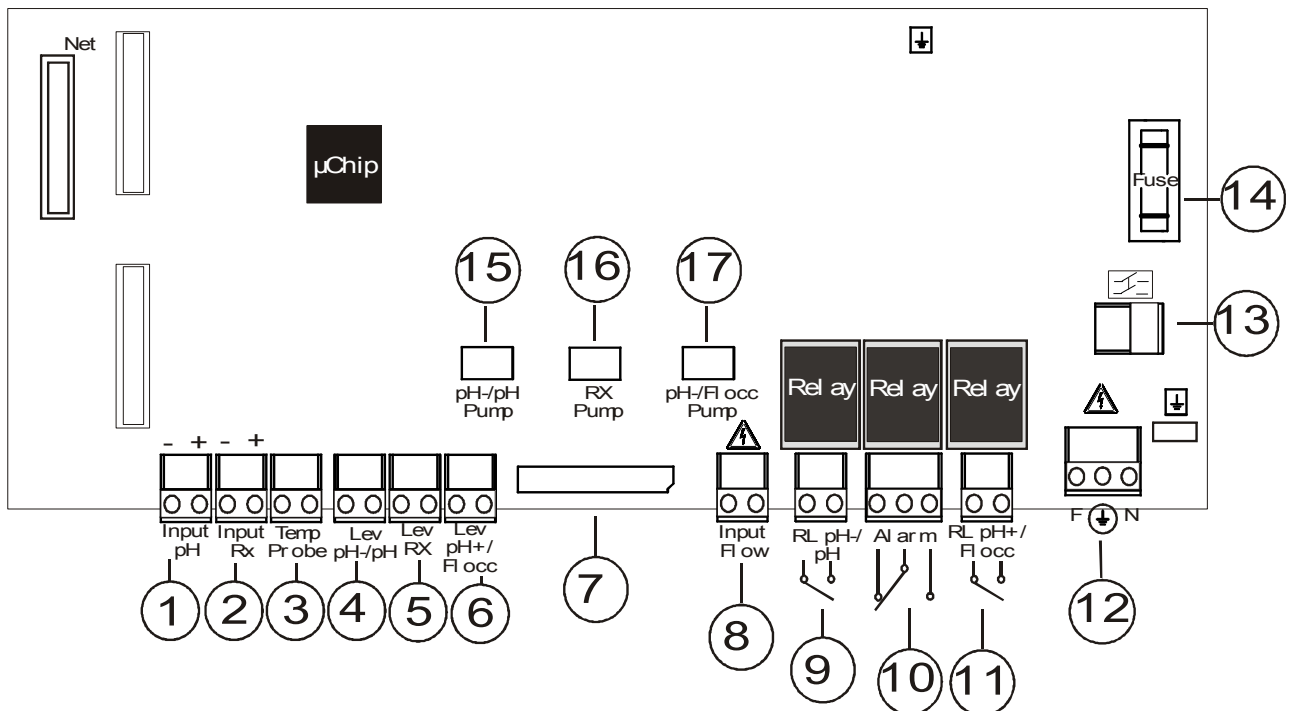

## 7. CALIBRATION MENU

### 7.1 Calibration







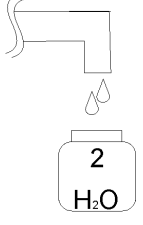
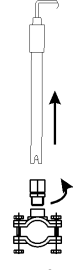
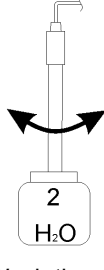
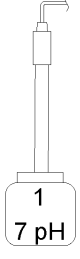
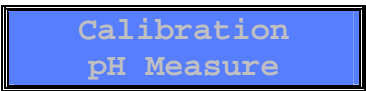

Before proceeding, the calibration must be enabled. Scroll down the menu **Advanced**→**Cal**, the display will show:

Calibration Menu Display	Settings
	Press <b>ENTER</b> to access the menu.
	Press <b>ENTER</b> and the + and – keys to modify the calibration. Select <b>Full</b> and confirm with <b>ENTER</b> .

Exit the menu and return to the normal system status.

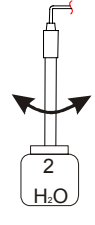
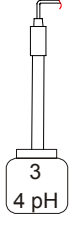



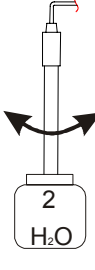
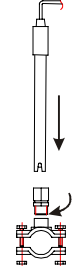

### 7.1.1 Calibration of pH probe

<p>①</p>  <p>Get some water</p>	<p>②</p>  <p>Remove the probe from the probe holder</p>	<p>③</p>  <p>Wash the probe</p>
<p>④</p>  <p>Keep the probe in the buffer solution pH 7</p>	<p>⑤</p>  <p>Press the <b>Cal</b> key for 3 seconds and use it to confirm the pH measurement</p>	<p>⑥</p>  <p>Press <b>Cal</b> to start calibration with a buffer solution pH 7</p>
<p>⑦</p>  <p>The calibration takes 1 minute</p>	<p>⑧</p>  <p>Probe quality</p>	<p>⑨</p>  <p>Wash the probe</p>
<p>⑩</p>  <p>Keep the probe in the buffer solution pH 4</p>	<p>⑪</p>  <p>Press <b>Cal</b> to start calibration with a buffer solution pH 4</p>	<p>⑫</p>  <p>The calibration takes 1 minute</p>
<p>⑬</p>  <p>Probe quality</p>	<p>⑭</p>  <p>Wash the probe</p>	<p>⑮</p>  <p>Put the probe back in the probe holder and press <b>Cal</b> to finish</p>

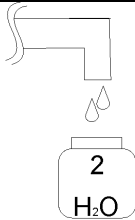
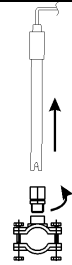
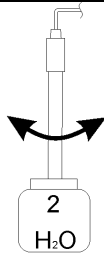
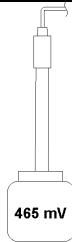
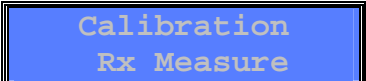
## 7.1.2 Calibration of Redox probe

To carry out this calibration the Redox measurement must be enabled.

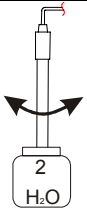
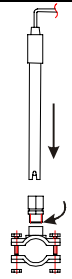
<p>①</p>  <p>Get some water</p>	<p>②</p>  <p>Remove the probe from the probe holder</p>	<p>③</p>  <p>Wash the probe</p>
<p>④</p>  <p>Keep the probe in the buffer solution 465 mV</p>	 <p>⑤</p> <p>Press the <b>Cal</b> key for 3 seconds and use it to confirm the Rx measurement</p>	 <p>⑥</p> <p>Press <b>Cal</b> to start calibration with a buffer solution 465 mV</p>
 <p>⑦</p> <p>The calibration takes 1 minute</p>	 <p>⑧</p> <p>Probe quality</p>	<p>⑨</p>  <p>Wash the probe</p>
<p>⑩</p>  <p>Put the probe back in the probe holder and press <b>Cal</b> to finish</p>		

## 8. PROGRAMMING

The programming menu can be accessed by simultaneously pressing the **Cal** and **Set** keys for at least 3 seconds.

Upon release of the keys the display will show:

<i>Language Display</i>	<i>Settings</i>
	Press <b>Enter</b> and the + and – keys to change the language: FR, EN, IT, ES, DE

The menu will show a different display according to the chosen configuration:



**Configuration A:** pH-/Rx/pH+



**Configuration B:** pH/Rx/Flocc

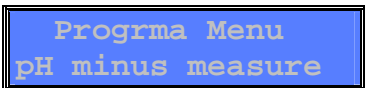
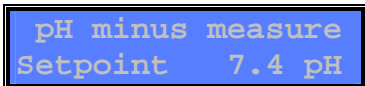
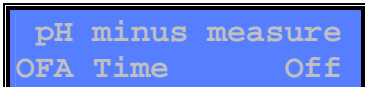
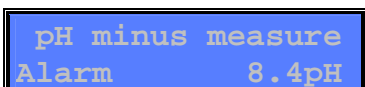
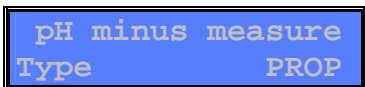

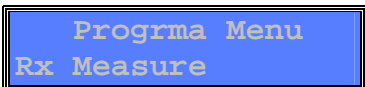
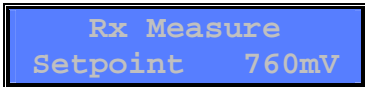

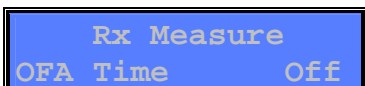
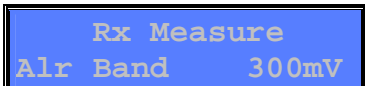
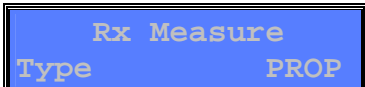
For further details please see the menu **Advanced→Configuration**

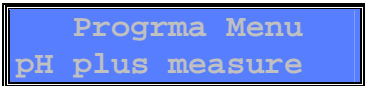
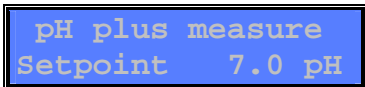
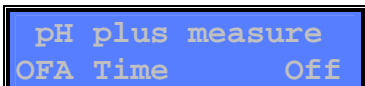
To prime the **pH-/pH** pump, press the **UP** button for at least 3 seconds and release it to stop the operation. To prime the **pH+/FLOCC** pump repeat the same procedure pressing the **DOWN** button for at least 3 seconds, for to prime the **Redox** pump press the **UP** and **DOWN** keys together.



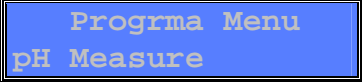

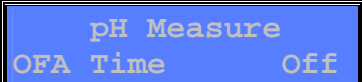

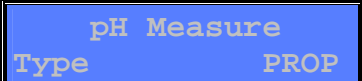
<i>pH Minus measurement display (A configuration)</i>	<i>Settings</i>
	Use <b>Enter</b> to access the sub-menus: <ul style="list-style-type: none"> <li>• Setpoint</li> <li>• OFA time</li> <li>• Alarm</li> <li>• Type</li> </ul>
	Press <b>Enter</b> and the + and - keys to modify the Set Point value which ranges from (Set Point pH Plus + 0.4 pH) to 14 pH.
	Press <b>Enter</b> and the + and - keys to set the OFA time on OFF or from 1 to 240 min (see Paragraph 9.5).
	Press <b>Enter</b> and the + and - keys to set the alarm ranging from Set Point + 0.1 pH to 14 pH. This alarm is shown on the display.
	Press <b>Enter</b> and the + and - keys to change the dosing type. <ul style="list-style-type: none"> <li>• PROP (see Paragraph 9.1).</li> <li>• ON/OFF (see Paragraph 9.3).</li> <li>• OFF (dosing disabled)</li> </ul>

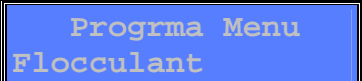
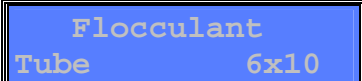
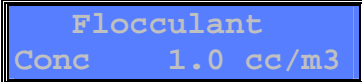
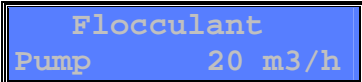
<b>Redox measurement display (A and B configuration)</b>	<b>Settings</b>
	Use <b>Enter</b> to access the sub-menus: <ul style="list-style-type: none"> <li>• Setpoint</li> <li>• Sp Type</li> <li>• OFA time</li> <li>• Alr Band</li> <li>• Type</li> </ul>
	Press <b>Enter</b> and the + and - keys to change the Set Point value (0÷1500 mV).
	Press <b>Enter</b> and the + and - keys to change the Set Point type. <ul style="list-style-type: none"> <li>• Low</li> <li>• High</li> </ul>
	Press <b>Enter</b> and the + and - keys to set the OFA time to OFF or from 1 to 240 min. (see Paragraph 9.5)
	Press <b>Enter</b> and the + and - keys to set the band alarm from 100 to 300 mV.
	Press <b>Enter</b> and the + and - keys to change the dosing type. <ul style="list-style-type: none"> <li>• PROP (see Paragraph 9.2).</li> <li>• ON/OFF (see Paragraph 9.4).</li> <li>• OFF (dosing disabled)</li> </ul>

<b>pH Plus measurement display (A configuration)</b>	<b>Settings</b>
	Use <b>Enter</b> to access the sub-menus: <ul style="list-style-type: none"> <li>• Setpoint</li> <li>• OFA time</li> <li>• Alarm</li> <li>• Type</li> </ul>
	Press <b>Enter</b> and the + and - keys to modify the Set Point value which ranges from 0 pH to (Set Point pH Minus - 0.4 pH).
	Press <b>Enter</b> and the + and - keys to set the OFA time to OFF or from 1 to 240 min (see Paragraph 9.5).
	Press <b>Enter</b> and the + and - keys to set the alarm ranging from 0 pH to Set Point - 0.1 pH. This alarm is shown on the display.
	Press <b>Enter</b> and the + and - keys to change the dosing type. <ul style="list-style-type: none"> <li>• PROP (see Paragraph 9.1).</li> <li>• ON/OFF (see Paragraph 9.1).</li> <li>• OFF (dosing disabled)</li> </ul>

<i>pH measurement display (B configuration)</i>	<b>Settings</b>
	Use <b>Enter</b> to access the sub-menus: <ul style="list-style-type: none"> <li>• Setpoint</li> <li>• Dos type</li> <li>• OFA time</li> <li>• Alr Band</li> <li>• Type</li> </ul>
	Press <b>Enter</b> and the + and - keys to change the Set Point value (0÷14 pH)
	Press <b>Enter</b> and the + and - keys to change the Set Point type. <ul style="list-style-type: none"> <li>• Acid</li> <li>• Alkaline</li> </ul>
	Press <b>Enter</b> and the + and - keys to set the OFA time to OFF or from 1 to 240 min. (see Paragraph 9.5)
	Press <b>Enter</b> and the + and - keys to set the band alarm from 1 to 3 pH.
	Press <b>Enter</b> and the + and - keys to change the dosing type. <ul style="list-style-type: none"> <li>• PROP (see Paragraph 9.2).</li> <li>• ON/OFF (see Paragraph 9.4).</li> <li>• OFF (dosing disabled)</li> </ul>

<i>Flocculant measurement display (B configuration)</i>	<b>Settings</b>
	Use <b>Enter</b> to access the sub-menus: <ul style="list-style-type: none"> <li>• Hose</li> <li>• Conc.</li> <li>• Pump</li> </ul>
	Use <b>Enter</b> to modify the dimensions of the hose (3x7 or 6x10mm) and the system automatically calculates the flow rate with the other hose without changing any parameters (the factory-set hose is 6x10).
	Enter the concentration value of the product to be dosed with the 3x7 hose. This value ranges from 1 to 4cc/m3. With the 6x10 hose the range is 1 to 15cc/m3.
	Enter the value of the system recirculation pump. It ranges from 2 to 100m³/h

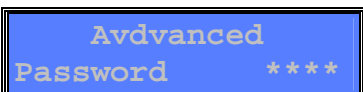

<b>Advanced Display</b>	<b>Settings</b>
	Use <b>Enter</b> to access the sub-menus: <ul style="list-style-type: none"> <li>• Pump config.</li> <li>• Relay config</li> <li>• Temp.</li> <li>• Flow</li> <li>• Cal.</li> <li>• Password</li> </ul>
	Press <b>Enter</b> to modify the pump configuration: <ul style="list-style-type: none"> <li>• <b>Configuration A:</b> The first pump on the left carries out the pH- function, the pump in the middle the Redox function and the one on the right carries out the pH+ function, (<b>pH-/Rx/pH+</b>).</li> <li>• <b>Configuration B:</b> The first pump on the left carries out the pH function, the pump in the middle the Redox function and the one on the right carries out the Flocculant function, (<b>pH/Rx/Flocc</b>).</li> </ul>
	Press <b>Enter</b> and the + and - keys to modify the outlet relay setting according to the Redox measurement (Rx pump) or according to an alarm condition (Alarm).
	Press <b>Enter</b> and the + and - keys to set the compensation temperature from 1 to 100°C. If a temperature probe is connected, the menu item will not be displayed as the system will compensate automatically with the value read by the probe itself.
	Press <b>Enter</b> and the + and - keys to set the flow to OFF or ON. This item enables or disables the <b>Flow</b> inlet (see. Paragraph 10.0).
	Press <b>Enter</b> and the + and – keys to set the calibration to OFF or enable it to ON (Full)
	Press <b>Enter</b> to set the system access and modification password. Use the + key to modify the figure and the – key to scroll to the next figure and confirm with <b>Enter</b>

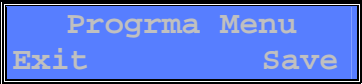
Press **Esc** to exit any menu and confirm the settings by pressing **Enter**.

<b>Display</b>	<b>Settings</b>
	Press the + and – keys to choose Save or NoSave, i.e. to save the settings or not and press <b>Enter</b> to confirm.

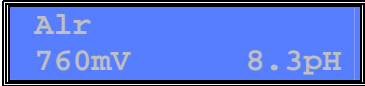
## DISPLAY VIEW WITH THE SYSTEM ON STAND-BY

<b>Stand-by display (Configuration A)</b>	<b>Operation</b>
	<p>The display is divided into 4 parts:</p> <ul style="list-style-type: none"> <li>• On the upper left hand side the alarm is shown, when present.</li> <li>• On the lower left hand side the value read by the Rx probe is shown.</li> <li>• On the lower right hand side the value read by the pH probe is shown</li> </ul>

<b>Stand-by display (Configuration B)</b>	<b>Operation</b>
<p>1</p> 	<p>The display is divided into 4 parts:</p> <ul style="list-style-type: none"> <li>• On the upper left hand side the alarm is shown, when present.</li> <li>• On the upper right hand side three views are displayed: <ul style="list-style-type: none"> <li>○ The first is the stand-by system</li> <li>○ The second shows the cc countdown dosed by the pump</li> <li>○ The third is the waiting time until the next dosing with the message FLOC.</li> </ul> </li> <li>• On the lower left hand side the value read by the Rx probe is shown.</li> <li>• On the lower right hand side the value read by the pH probe is shown</li> </ul>
<p>2</p> 	
<p>3</p> 	

\*If Advanced→Flow=On and during Flocculant dosing, the recirculation pump stops and blocks the system dosing, when the pump restarts, the Flocculant will restart the cc dosing calculated from the start.

### SHORTCUTS

To access the shortcut menu press the **SET** key for at least 3 seconds when the system is in stand-by.

<b>Display Set (Configuration A)</b>	<b>Operation</b>
	<p>The pH- value flashes. It can be modified using the + and – keys and confirmed using <b>Enter</b>. For the pH+ and Rx value, repeat the same procedure, press <b>Enter</b> to confirm and exit.</p>

<b>Display Set (Configuration B)</b>	<b>Operation</b>
	<p>The pH- value flashes. It can be modified using the + and – keys and confirmed using <b>Enter</b>. For the Redox and Flocculant value, repeat the same procedure, press <b>Enter</b> to confirm and exit.</p>

## 9. DOSING METHOD

The control of the pumps in the pH and Redox scale is carried out through the PWM function.

The proportional band is fixed on the values pH0.8 and Redox = 120 mV

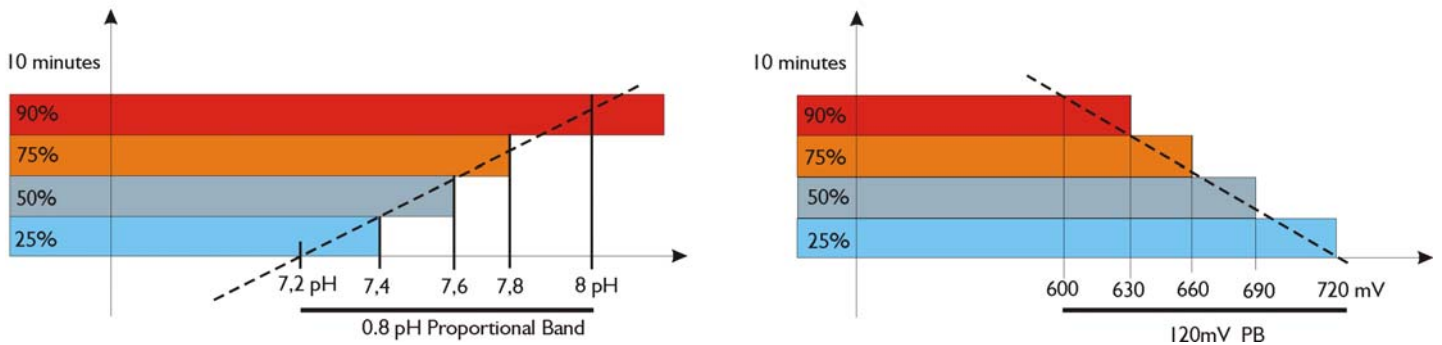

### 9.1 Proportional dosing pH-/pH+

The instrument allows the chemical measurement to be controlled and modified through the pH- and pH+ Set Point automatically; adjusting the dosing through the pH-/pH+ motor controlled in Proportional Time.

The dosing below is obtained by setting the following parameters:

- Set point pH- = 8.10 pH
- Set point pH += 6.90 pH
- Proportional Band = 0.80 pH

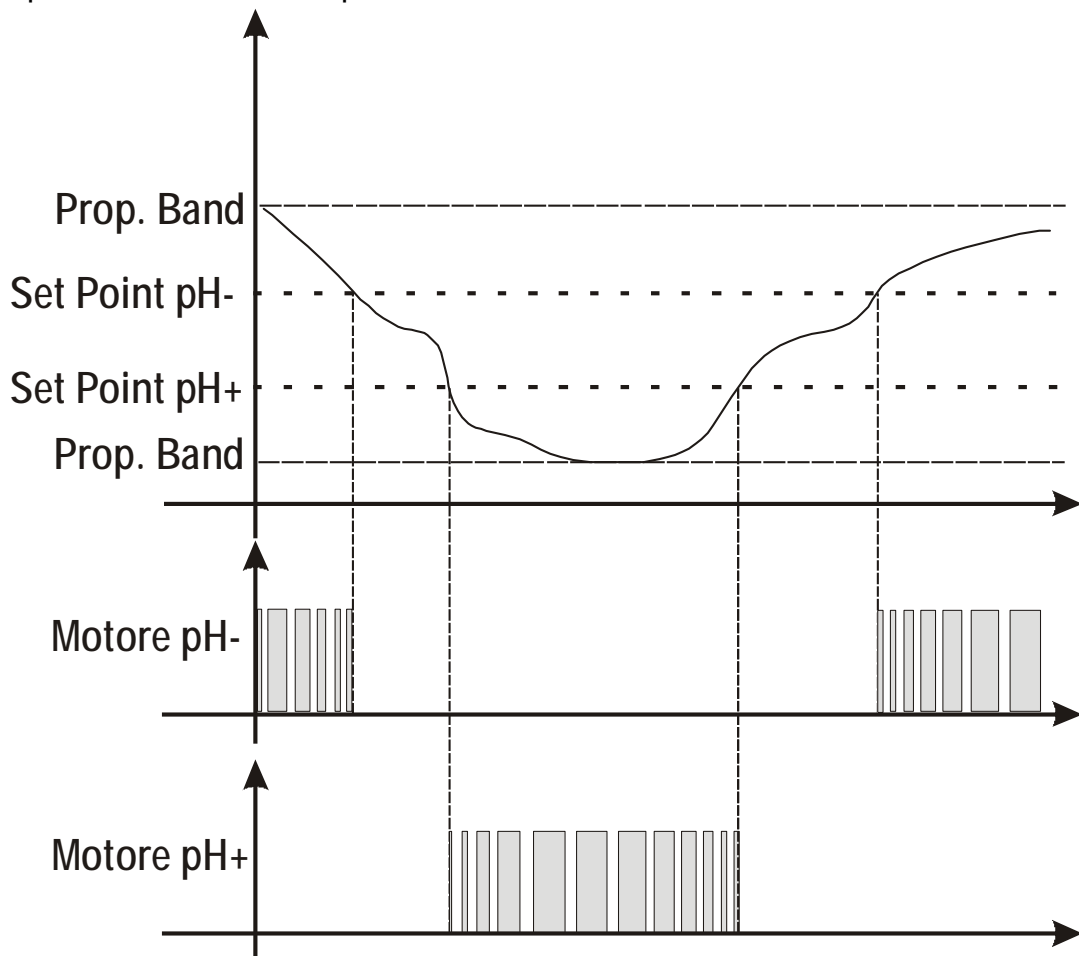



### 9.2 pH/Redox proportional dosing

The instrument allows the chemical measurement to be controlled and modified through the pH Set Point automatically; adjusting the dosing through the pH motor controlled in Proportional Time.

The dosing below is obtained by setting the following parameters:

- Set point pH = 7.20 pH
- Type of Dosing = Alkaline
- Proportional Band = 0.80 pH

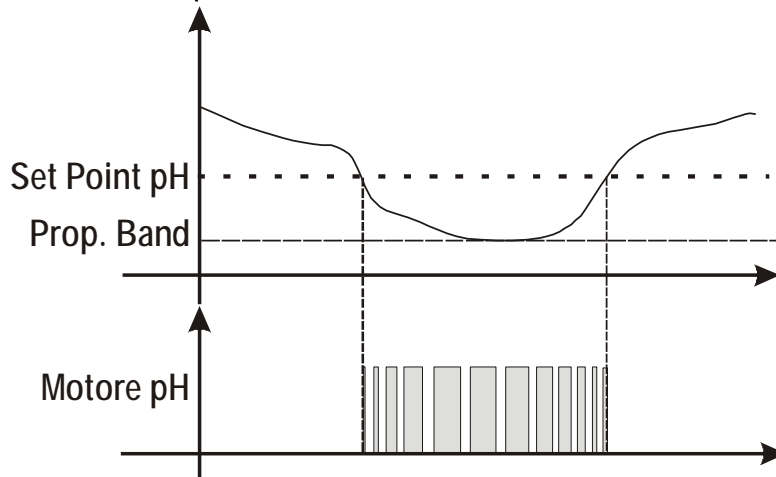

### 9.3 ON/OFF pH-/pH+ dosing

The instrument allows the chemical measurement to be controlled and modified through the pH- e pH+ Set Point automatically; adjusting the dosing through the pH-/pH+ motors controlled in ON/OFF.

The dosing below is obtained by setting the following parameters:

- Set point pH- = 8.10 pH
- Set point pH += 6.90 pH

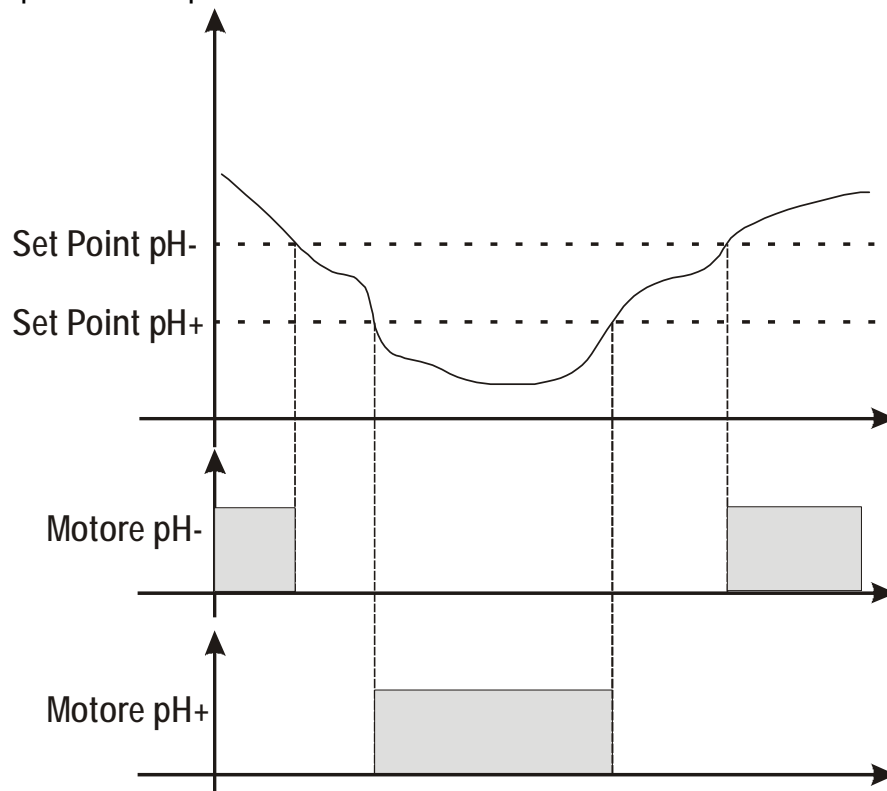

## 9.4 ON/OFF pH/Redox dosing

The instrument allows the chemical measurement to be controlled and modified through the pH Set Point automatically; adjusting the dosing through the pH motor controlled in ON/OFF. The dosing below is obtained by setting the following parameters:

- Set point pH = 7.20 pH
- Type of Dosing = Alkaline

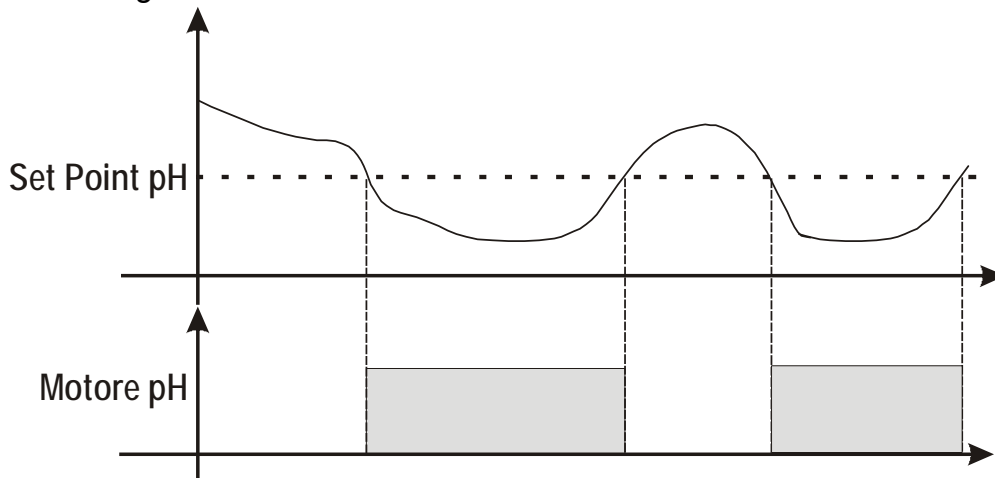

## 9.5 Alarm for the pH/Redox Set Point

When the alarm band is set, a work window is created. If the allowed limits are exceeded the alarm relay closes and remains closed until the measurement is reset or the enter key is pressed to deactivate the alarm.

When the OFA time (Over Feed Alarm) is set, the dosing time of Set Point pH/Redox in time is controlled with two alarms:

- First alarm at 70% of the time set is seen on the display, the alarm relay closes.
- Second alarm at 100% of the time set is seen on the display and the alarm relay closes and the pH/Redox motor is blocked.

Press the Enter key to eliminate the alarm and initialise the OFA time.

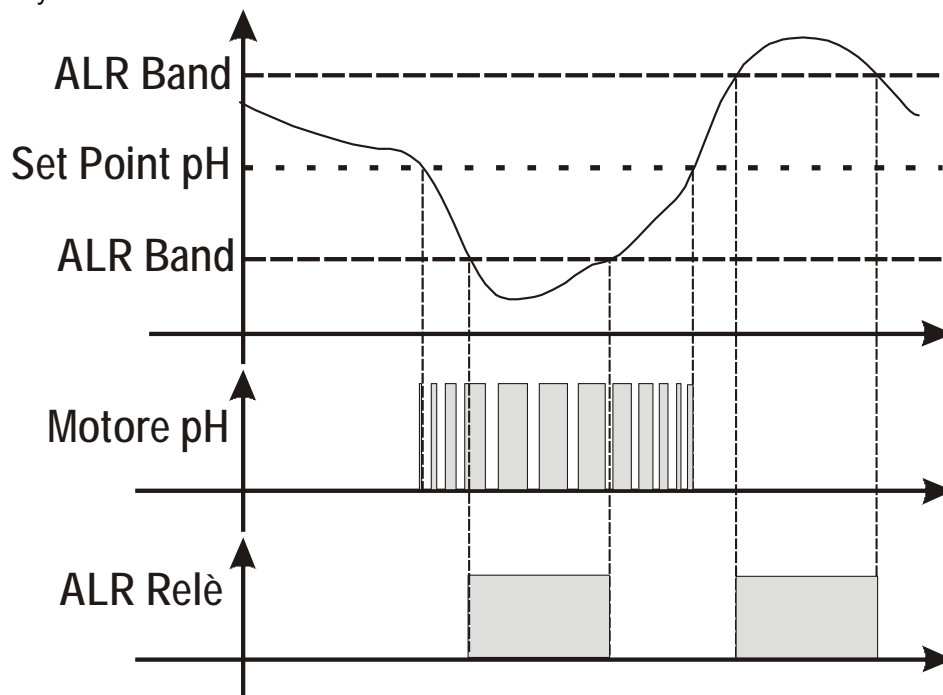

**Note:** The operation is the same for the pH-/pH+.

## 10. ACTIVATIONS

- **Flow Function**

Through the recirculation pump.

High voltage input 100 ÷ 240 Vac, the dosing system is switched on.

High voltage input is off (the recirculation pump is switched off), the dosing system shows FLOW flashing.

## 11. ALARMS

**Lev pH-**= pH product level probe alarm.

**Lev pH+**= pH product level probe alarm.

**Lev pH**= pH product level probe alarm.

**Lev Flocc**= Flocculant product level probe alarm.

**OFA pH/Redox**= Set Point not reached with the OFA time set\*

**pH/Redox Band**= Shown when the value read is outside the SetPoint of +/- the band value set.

\*At 70% of the time set the system shows and activates the alarm relay, at 100% it blocks the motor. Press the Enter key to reset the alarm.

Press the Enter key with the alarm active and its relay is deactivated only remaining shown on the display.

## 12. PRE-DEFINED CONTROL PARAMETERS

**To reset default values and settings:**

- Disconnect the device
- Hold down the + and – keys simultaneously and connect the device
- Confirm the choice to reset the default parameters

**Default parameters:**

- Configuration = **A (pH-/Rx/pH+)**
- Language = **UK**
- Set Point pH- = **7,4 pH; OFF; Alr 8,4 pH; PROP**
- Set Point Rx = **750mV; Low; OFF; Alr Band 300mV; PROP**
- Set Point pH+ = **7,0 pH; OFF; Alr 6,0 pH; PROP**
- Temperature = **25°C**
- Calibration = **FULL**
- Flow Input= **ON**
- Password = **Disabled**

### 13. LIST OF POSSIBLE ANOMALIES AND RELATIVE SOLUTIONS

ANOMALY	CAUSE	SOLUTION
The instrument always indicates pH 7.00	Problem with the cable and/or connector.	1) Check for possible short circuits on the electrode ↔ instrument connection cable (between the cable's core and the external shielding). 2) Make sure that there are no traces of humidity and/or condensation on the connector of the probe or the device. 3) Make sure that 100 Ω resistance is present between terminals 11 and 12.
The instrument always indicates a high or continuously unstable value	The electrode's connection cable is damaged.	Check the cable.
	There is an air bubble in the electrode's membrane.	Place the electrode vertically and shake it slightly until the air bubble rises. <b>N.B.:</b> The electrode must be vertical or tilted by a maximum of 45°.
	Electrode worn.	Replace the electrode.
	Connection cable too long or too close to an electrical wire: Disturbance.	Reduce the distance between the device and the probe.
Impossible to calibrate the pH 7 value	Unsuitable buffer solution.	Make sure that the solution used is pH 7.
		Check the buffer solution pH using an electronic pH-meter.
Error shown on the display	Problem on probe's porous material, dirt deposits.	Use a new pH 7 buffer solution and restart calibration.
Calibration quality of pH probe < 20%	Problem on probe's porous material, dirt deposits.	Make sure that the probe's porous material is in good condition; wash the electrode using a diluted acid-based solution and dry with a soft cloth.
Impossible to calibrate the pH 4 value	Unsuitable buffer solution.	Electrode worn.
		Replace the electrode.
		Make sure that the solution used is pH 4.
Error shown on the display	Problem with the electrode bulb.	Check the buffer solution pH using an electronic pH-meter.
		Use a new pH 4 buffer solution and restart calibration.
Calibration quality of pH probe < 20%	Problem with the electrode bulb.	Make sure that the electrode bulb is not damaged. Make sure that it did not become dry outside of the water. As a last resort, clean the electrode and leave it immersed in the water for a few hours.
		Replace the electrode.
Slow electrode response	Electrode electrostatically charged.	Replace the electrode.
		During the calibration phase, the electrode MUST NOT be dried with a cloth or paper; let it drip.

## 14. HANDLING

### Hose replacement:

①

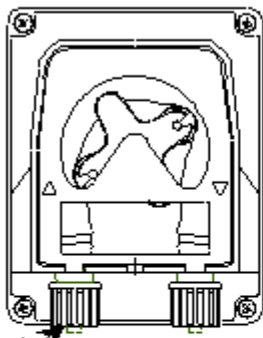

Release the cover by pulling the left connector upward.

②

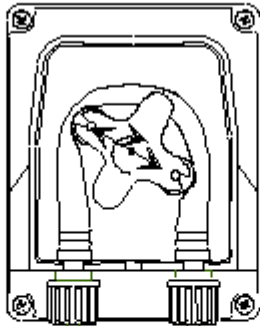

Position the roller at 20 past 10, turning it in the direction of the circular arrow.

③

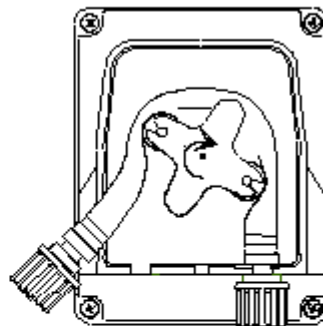

Completely release the left connector, holding it taut towards the outside, and turn the roller in the direction of the circular arrow so that the hose is freed up to the right connector.

④

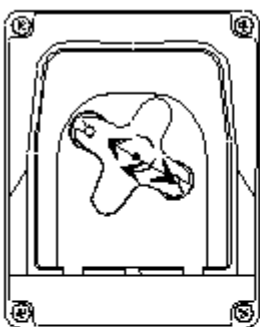

Position the roller at 20 past 10, turning it in the direction of the circular arrow.

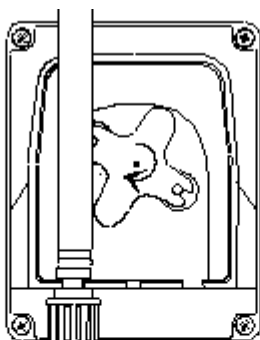

Insert the left connector into the relative housing and pass the hose under the roller's guide. Turn the probe holder in the direction of the circular arrow, simultaneously accompanying the hose into the pump's head, until the right connector is reached.

⑥

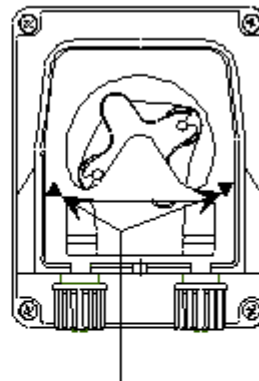

Arrows indicating the liquid's direction

Position the pump's cap, according to the direction of the arrows (▲▼) and press its surface hard so that it is properly locked into place.

## 15. STORING THE PUMP AFTER USE

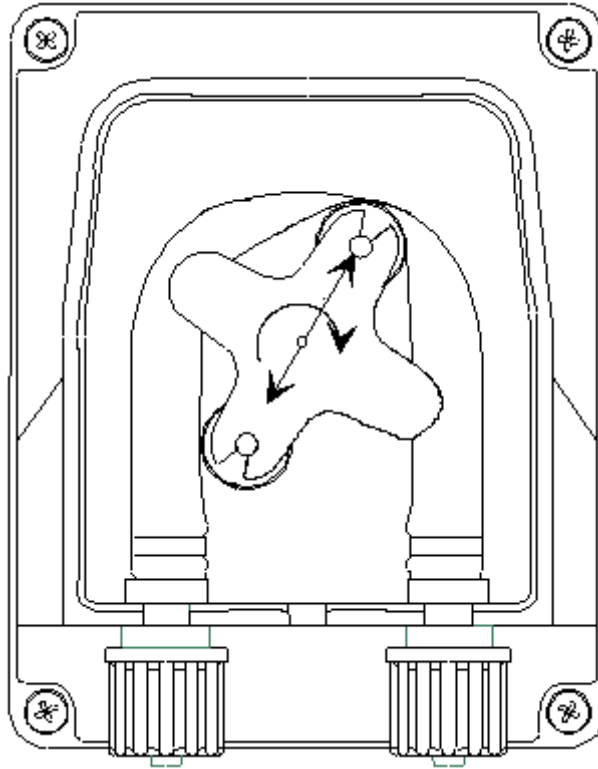

When the regulation device must be stored, clean water should be pumped through the hose in order to rinse it.

Then position the probe holder at 7h05, turning in the direction indicated by the circular arrow. These two precautions will facilitate the subsequent reactivation of the unit.

# WARNINGS

## PRODUCTS TO BE USED:

- pH Reduction: product with a sulphuric acid base, easily found on the market.
- pH Increase: product with an alkaline acid base

## PRODUCTS NOT RECOMMENDED

- Do not use hydrochloric acid.

Ask the installer about all other products.

## PROBE WARNINGS

- Handle the probe with CARE.
- DO NOT INSERT AN EXCESSIVE AMOUNT of chemical product prior to the probe.
- Storing the probe: Extract the pH probe from the relative probe holder. Store it in the original bottle filled with tap water. If necessary, close the probe holder using a plug the size of a 5 euro cent coin.

Since the pH electrode consists of glass parts, handle it with care.

All of our electrodes are tested on the production line before being packaged.

**Repairs of electrodes are not foreseen by the warranty unless they do not function when they are activated for the first time. Packaging not included.**

In this case, in order for the probe to be accepted for examination, it absolutely must be sent in the original packaging with the relative bottle filled with water.

**CAUTION: VAPOURS**

