

SWIMMING POOL HEAT PUMP UNIT

ECO ® - series

Installation & Instruction manual



Contents

SWIMMING POOL HEAT PUMP UNIT	1
CONTENTS	2
1. PREFACE	3
2. SPECIFICATIONS	4
2.1 Performance data of ECO Swimming Pool Heat Pump Unit	4
2.2 Dimensions of Swimming Pool Heat Pump	5
3. INSTALLATION OF THE HEAT PUMP UNIT	6
3.1 Installation items:	6
3.2 Heat pump location	6
3.3 How close to the pool?	6
3.4 Check valve installation	7
3.5 Typical configuration	7
3.6 Setting the bypass	8
3.7 Electrical wiring	9
3.8 Initial startup of the unit	9
3.9 Condensation	9
4. GUIDELINES	10
4.1 Water chemistry	10
4.2 Wintering	10
4.3 Spring startup	10
4.4 Owner inspection	11
5. MAINTENANCE AND INSPECTION	12
5.1 Maintenance	12
5.2 Trouble shooting guide	12
5.3 Check list at installation	13
6. DETAILED SPECIFICATIONS	14
6.1 Electrical wiring diagram of the heat pump	14
7. WARRANTY AND RETURN	15
7.1 Warranty	15
7.2 RMA request form	16

1. Preface

- In order to provide our customers with quality, reliability and versatility, this product has been made to strict producing standards. This manual includes all necessary information about installation, debugging, discharging and maintenance. Please read this manual carefully before you open or maintain the unit. The manufacturer of this product will not be held responsible if someone is injured or the unit is damaged, as a result of improper installation, debugging or unnecessary maintenance. It is vital that the instructions within this manual are adhered at all times. Qualified personnel must install the unit.
- A qualified installer, centre, personnel or an authorized dealer, can only repair the unit.
- Maintenance and operation must be carried out according to the recommended time and frequency, as stated in this manual.
- Use genuine standard spare parts only.
Failure to comply with these recommendations will void warranty.
- The Swimming Pool Heat Pump Unit heats the swimming pool water and keeps the temperature constant.

Our heat pump has following characteristics:

Durable

The heating exchanger is made of PVC & Titanium[®] tube, which can withstand prolonged exposure to swimming pool water.

Easy operation

The unit is very easy to operate: switch it on and set the desired pool water temperature.

Quiet operation

The unit comprises an efficient rotary compressor and a low-noise fan motor, which guarantees its quiet operation.

The unit can heat your swimming pool water when the air temperature is 10°C or higher.

Low cost

The operational cost is very low due to its high performance.

2. Specifications

2.1 Performance data of ECO Swimming Pool Heat Pump Unit

Unit	Model	ECO-3	ECO-5	ECO-8	ECO-10
Heating Capacity	kW	3,0	4,5	7,8	9,5
	BTU/h	10200	15300	26500	32500
Power Input	kW	0,73	1,05	1,65	1,97
Maximum Pool Volume	m ³	12	18	30	40
Running Current	A	3,3	4,8	7,5	10,0
COP		4,1	4,3	4,7	4,8
Power Supply	V/Ph/Hz	220-240/1/50	220-240/1/50	220-240/1/50	220-240/1/50
Controller		Mechanical control			
Condenser		Titanium heat exchanger			
Compressor Quantity		1	1	1	1
Compressor		rotary	rotary	rotary	rotary
Refrigerant		R407C	R407C	R407C	R407C
Refrigerant quantity	Kg	0,6	0,8	1,5	2,1
Fan quantity		1	1	1	1
Fan Power Input	W	20	25	25	30
Fan Speed	RPM	950	900	900	890
Fan Direction		horizontal	horizontal	horizontal	horizontal
Noise at 2m	dB(A)	51	54	55	57
Water Connection	mm	50	50	50	50
Nominal Water Flow	m ³ /h	3 - 5	4 - 6	4 - 7	4 - 7
Water Pressure Drop (max)	kPa	10	10	12	15
Unit Net Dimensions	L/W/H mm	770/300/490	936/360/550	936/360/550	1010/370/615
Unit Shipping Dimensions	L/W/H mm	825/315/525	1090/390/580	1090/390/580	1170/415/645
Net Weight /Shipping Weight	Kg	29/32	36/39	54/57	63/67

Measurement conditions: Dry bulb: 24 °C , Wet bulb: 19 °C , water inlet temperature 27 °C

2.2 Dimensions of Swimming Pool Heat Pump

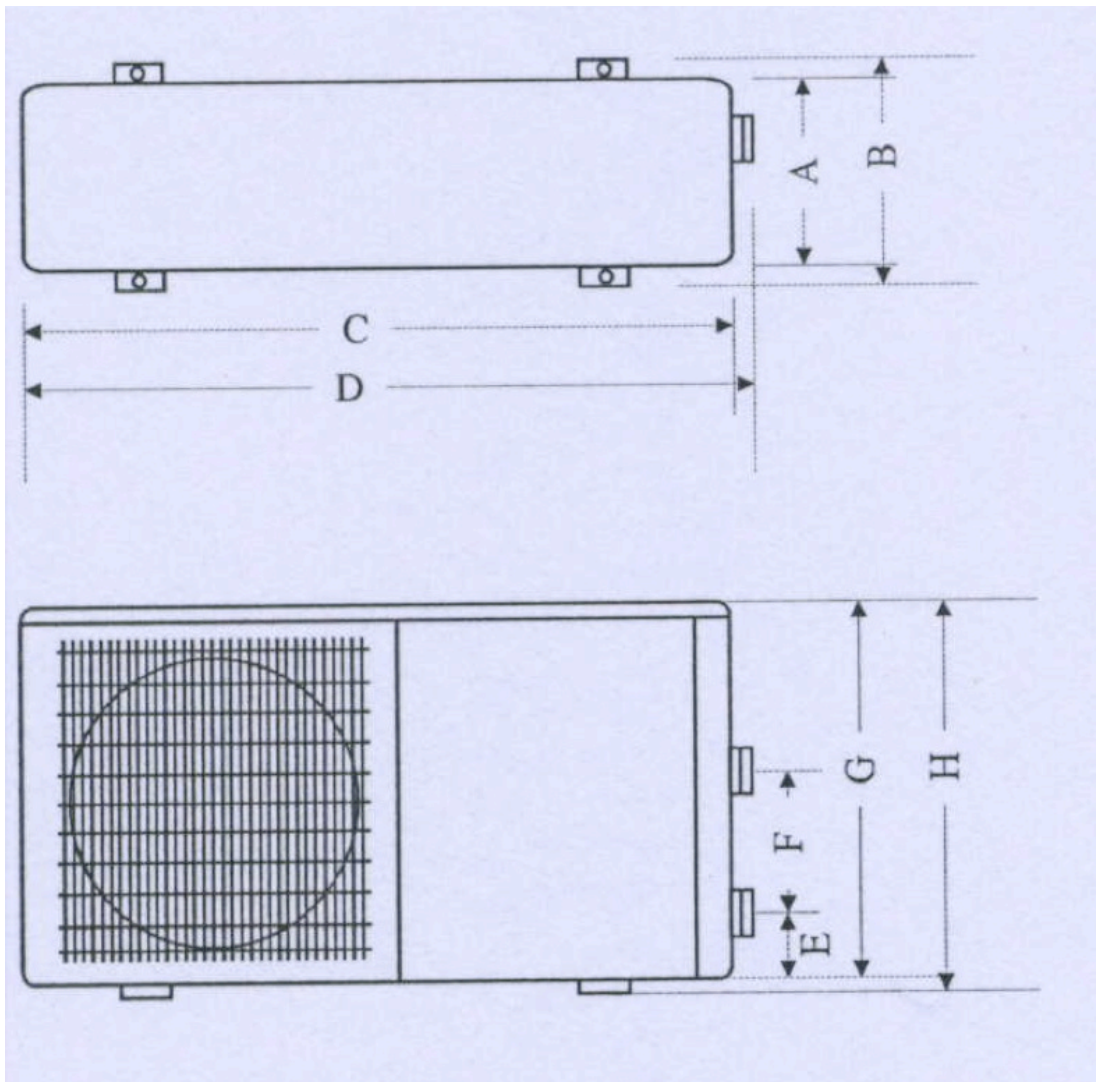

	A	B	C	D	E	F	G	H
ECO-3	213	293	770	810	80	200	455	485
ECO-5	280	360	936	970	80	200	521	551
ECO-8	280	360	936	970	80	200	521	551
ECO-10	301	370	1010	1050	83	270	585	615

3. Installation of the heat pump unit

3.1 Installation items:

The factory only provides the heat pump unit; the other items including an eventual bypass, in the illustration are necessary parts for the water system, provided by users or the installer.

Attention:

Please follow these steps when installing the heat pump:

1. All feeding of chemicals to the pool water has to be done downstream of the heat pump.
2. Install a bypass when the flow of the pool pump is more than 20% above the rated flow of the heat exchanger of the heat pump.
3. Install the heat pump above the level of the pool water.
4. Install the heat pump on a solid foundation and use the damping rubbers to eliminate vibrations and noise.
5. Always keep the unit straight up. If the unit has been tilted or put on his side, allow 24h before starting the unit.

3.2 Heat pump location

The unit may be installed virtually anywhere **outdoors**. For indoor pools please consult your supplier.

DO NOT put the unit in an enclosed area with a limited air volume where the unit discharge air will be re-circulated.

DO NOT put the unit next to shrubs, which can block the air inlet. Such locations deny a continuous source of fresh air, which reduces its efficiency and may prevent adequate heat delivery.

The picture below give the minimum required distances from each side of the heat pump.

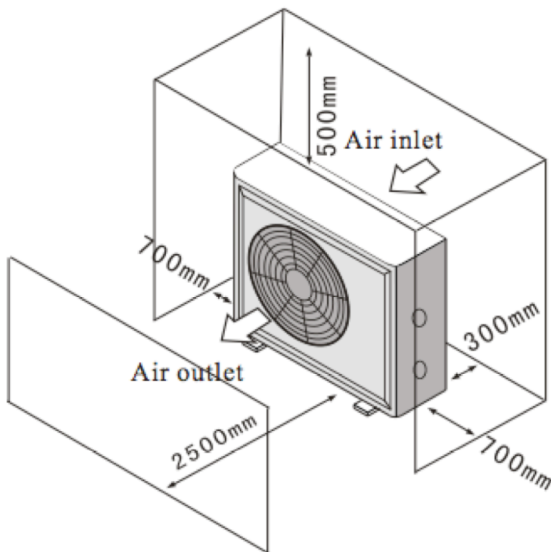

Install the heat pump where you have the best access to warm air during the swimming season

3.3 How close to the pool?

Install the heat pump as close to the swimming pool as possible to minimize the loss of heat through the piping. Put it on a solid base and place the rubber blocks under the heat pump to eliminate vibrations.

3.4 Check valve installation

Caution –Placement of the chlorinator, water balance equipment, and the placement of injectors of chemicals, are very important aspects of the installation. All addition of chemicals have to be done downstream from the heat pump. Failure to protect the heat pump unit from chemical damage is not covered under the warranty.

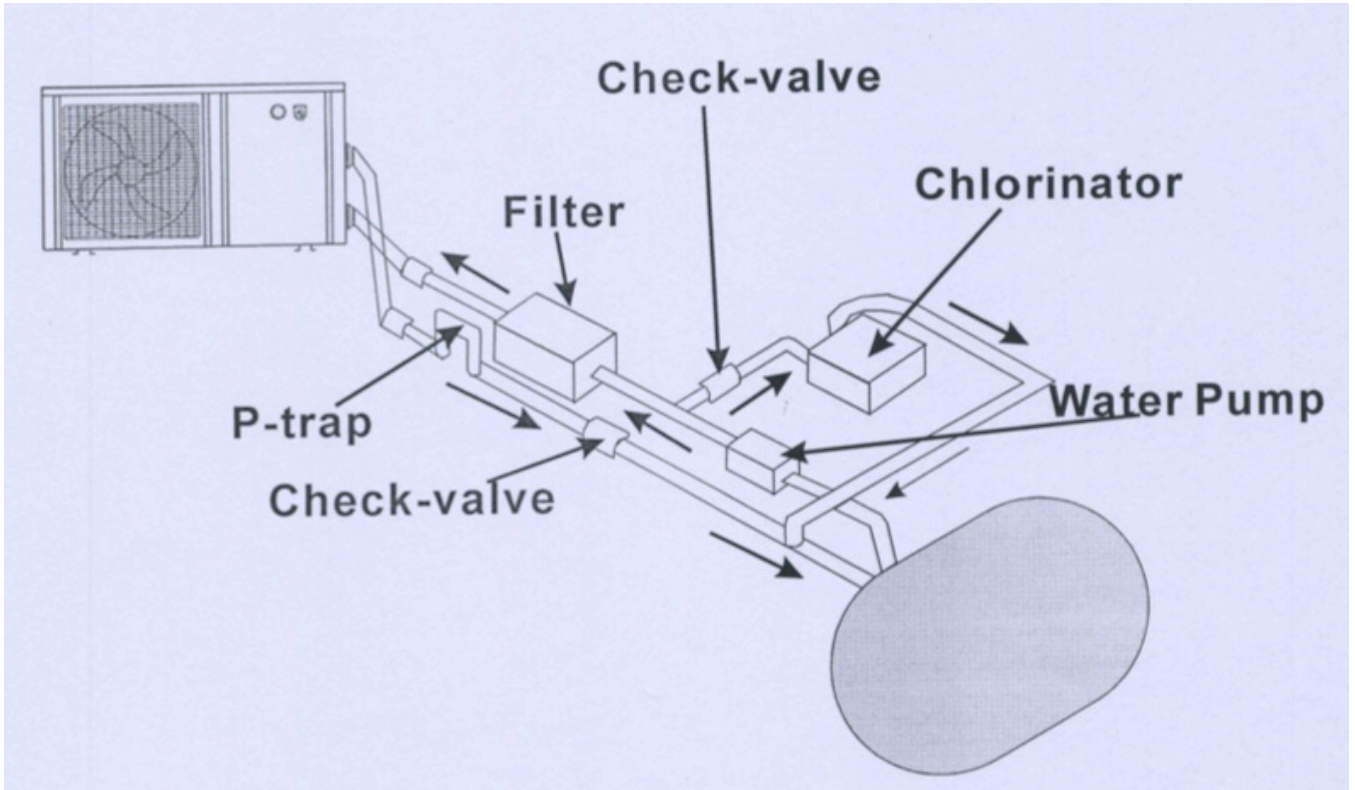

3.5 Typical configuration

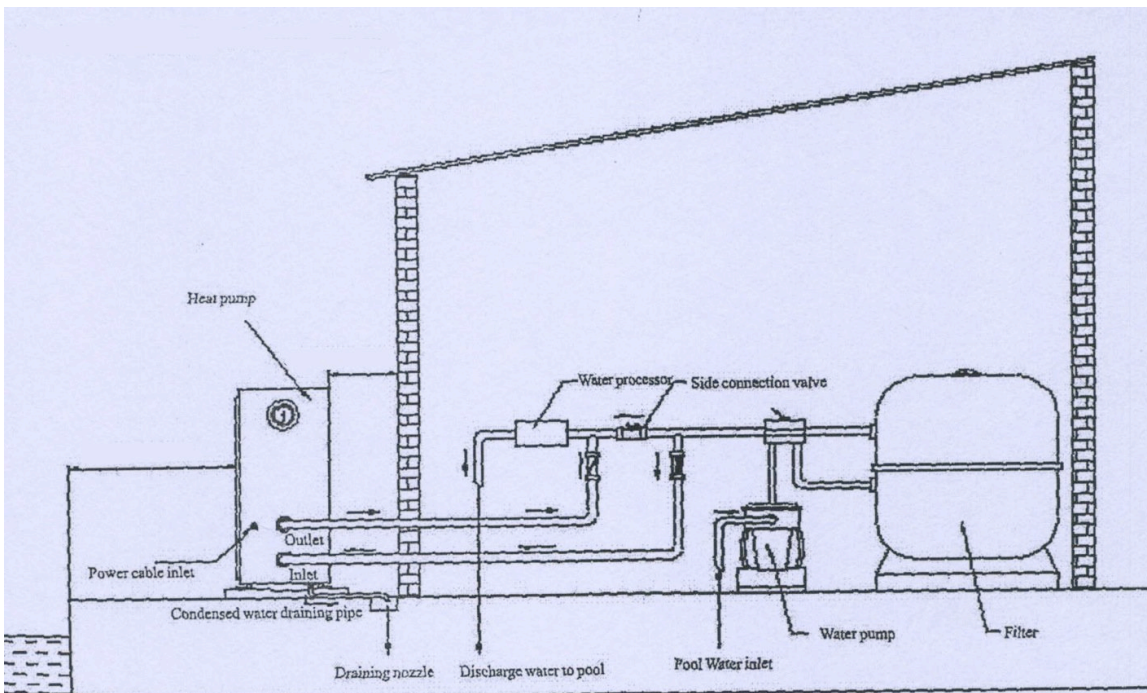

Note: the above piping connection is only an example for demonstration

3.6 Setting the bypass

With the bypass set correctly, your heat pump will deliver its best performance. The bypass has to be built as show below:

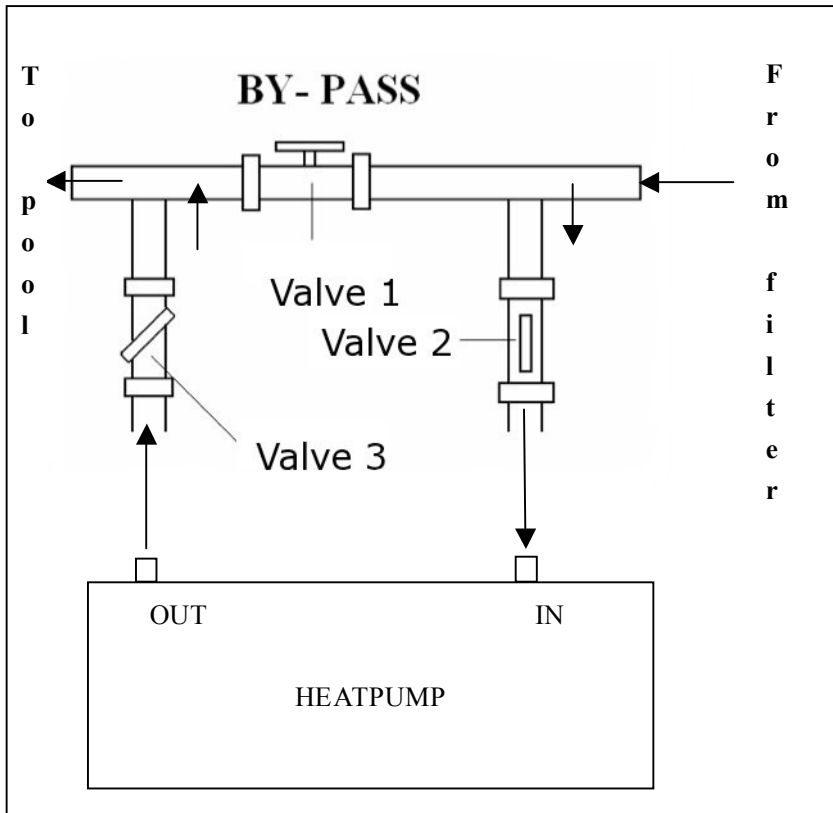

- VALVE 1
Slightly closed (water pressure increased with just 100 to 200 gr)
- VALVE 2
Completely open
- VALVE 3
Half way open

Setting the valves of the by-pass:

- set all 3 valves entirely open
- slightly close valve 1 (see also 3.8)
- close valve 3 about half way to adjust the refrigerant pressure

3.7 Electrical wiring

Note: - Verify the local power supply and the operating voltage of the heat pump. It is recommended to use a separate circuit breaker (slow type – D curve) for the heat pump together with the proper wiring characteristics (see table below). The current to the heat pump should only be applied when the filter pump is running. For example a relay controlled by the filter pump could be used to activate the current to the heat pump. Further connect the electrical supply to the junction box inside the unit. All ECO heat pumps require single-phase connection.

Grounding the heat pump is required to protect you against electrical shock caused by an eventual short circuit inside the unit.

Model	Power supply (Volt)	Circuit breaker (A)	Running current (A)	Cable diameter (mm ²) for cable length max 15m
ECO-3	220-240	16	3,3	1,5
ECO-5	220-240	16	4,8	1,5
ECO-8	220-240	20	7,5	2,5
ECO-10	220-240	20	10	2,5

Values in this table are only guidelines. Please check your local regulations.

The heat pump is not equipped with a flow switch or any other kind of water flow detection. **Therefore, the heat pump has to be wired electrically together with the filter pump to ensure water flow while the heat pump is running.**

3.8 Initial startup of the unit

Start up Procedure - after the installation is completed, you should follow these steps:

1. Set the by-pass valve 1 entirely open. Turn on your filter pump. Check for water leaks and verify flow to and from the pool.
2. Turn on the electrical power supply to the unit and turn the unit ON with the switch. Slightly close valve 1 until the heat pump starts.
3. After running a few minutes, check if the air leaving the side of the unit is cooler.
4. Allow the unit and pool pump to run 24 hours per day until desired pool water temperature is reached. When the set temperature is reached, the unit just shuts off. The unit will now automatically restart (as long as your pool pump is running) when the pool temperature drops more than 1 degree Celsius below set temperature.

Time Delay - the unit is equipped with a 3-minute built-in delay to protect control circuit components and to eliminate restart cycling and contactor chatter. This time delay will automatically restart the unit approximately 3 minutes after each circuit interruption. Even a brief power interruption will activate this delay and prevent the unit from starting until the 3-minute countdown is completed.

Several days are needed to bring the temperature of you swimming pool water to its required value.

3.9 Condensation

Since the Heat pump cools down the air about 8 - 12 °C, water may condense on the fins of the evaporator. If the relative humidity is very high, this could be as much as several liters an hour. Sometimes this condensation water is wrongly considered as swimming pool water.

4. Guidelines

4.1 Water chemistry

Special care should be taken to keep the chemical balance of your swimming pool within limits:

pH	7,0 – 7,4
free chlorine	0,5 – 1,2 mg/l
TAC	80 – 120 mg/l
salt	max 3g/l

IMPORTANT: failure to keep the swimming pool water between above limits will void the warranty

NOTE: when the concentration of one or more products mentioned above becomes too high, irrevocable damage to your heat pump may occur. Make sure that you always install water treatment equipment after the heat pump.

When an automatic chemical feeder is installed in the plumbing, it must be installed downstream of the heat pump.

A check valve must be installed between the heat pump and the chemical feeder to prevent back-siphoning of chemically saturated water into the heat pump where it will damage the components.

4.2 Wintering

Caution: failure to winterize could cause damage to the heat pump and will void warranty

In areas where freezing temperatures occur, you should protect your pump, filter and heat pump from the elements.

Perform the following steps to completely drain the heat pump:

1. Turn off the electrical power to the heat pump at the main breaker panel.
2. Shut off the water supply to the heat pump: close valves 2 and 3 on the by-pass completely.
3. Disconnect the water inlet and outlet and let the water drain from the heat pump.
4. Re-connect the water inlet and outlet loosely to prevent debris entering the connections.

4.3 Spring startup

If your heat pump has been winterized, perform the following steps when starting the system in the spring:

1. Inspect the system for any debris or structural problems.
2. Connect the water inlet and outlet unions firmly.
3. Turn on the filter pump to supply water to the heat pump. Adjust the by-pass to allow water flow through the heat pump.
4. Turn on the electrical power to the heat pump at the main breaker panel.

4.4 Owner inspection

The ECO heat pumps are designed and constructed to provide long performance life when installed and operated properly under normal conditions. Periodic inspections are important to keep your heat pump running safely and efficiently through the years.

The following basic guidelines are suggested for your inspection:

1. Make sure the front of the unit is accessible for future service.
2. Keep the surrounding areas of the heat pump clear of all debris.
3. Keep all plants and shrubs trimmed and away from the heat pump.
4. Keep lawn sprinkler heads from spraying on the heat pump to prevent corrosion and damage. Use a deflector if needed.
5. If the unit is installed under a very sharp roof pitch or under a roof without a gutter, a gutter or diverter should be fitted to prevent excessive water from pouring down onto the unit.
6. Do not use the heat pump if any part has been under water. Immediately call a qualified professional technician to inspect the heat pump and replace any part of the control system, which has been submerged.

The heat pump will produce condensation (water) while in operation. The heat pump base is designed to allow the condensation to exit through the bottom drain port. The condensation will increase as the outdoor air humidity level increases. Check the following at regular intervals to ensure proper condensate drainage:

1. Visually inspect and clear the bottom drain port of any debris that could clog the port.
2. Keep the air intake area and discharge area clear of debris so the airflow through the heat pump is not restricted. The cooler discharge air should not accumulate and be drawn into the side air intake coils.

During normal operation, the heat pump produces ten to twenty liters of condensate per hour. If condensate drainage is above this range during operation or if water continues to drain from the base when the heat pump is not in operation for more than an hour, a leak in the internal plumbing may have occurred. Call a qualified heat pump technician to investigate the problem.

NOTE: A quick way to verify that the water running through the drain is condensation water is to shut off the unit and keep the pool pump running. If the water stops running out of the base pan, it is condensation water. AN EVEN QUICKER WAY - TEST THE DRAIN WATER FOR CHLORINE - if there is no chlorine present, then it's condensation.

5. Maintenance and inspection

5.1 Maintenance

- Check the water supply to the unit often. Low water flow and air entering into the system should be avoided, as this will diminish the units' performance and reliability. You should clean the pool/spa filter regularly to avoid damage to the unit as a result of the dirty or clogged filter.
- The area around the unit should be dry, clean and well ventilated. Clean the side heating exchanger regularly to maintain good heat exchange and to save energy.
- Only a certified technician should service the operation pressure of the refrigerant system.
- Check the power supply and cable connection often. Should the unit begin to operate abnormally, switch it off and contact a qualified technician.
- In winter, please discharge all water from the water pump and other systems to prevent damage from freezing.
- You should discharge the water at the bottom of the heat pump if the unit will not work for an extended period of time. You should check the unit thoroughly and fill the system with water fully before using it for the first time after a prolonged period of no usage.

5.2 Trouble shooting guide

Improper installation will create an electrical hazard, which could result in death or serious injury to pool users, installers, or others due to electrical shock, and may also cause damage to property.

DO NOT attempt any internal adjustments inside the heater.

1. Keep your hands and hair clear of the fan blades to avoid injury.
2. If you are not familiar with your pool filtering system and heater:
 - a. **Do not** attempt to adjust or service without consulting your dealer, professional pool or air conditioning contractor.
 - b. Read the entire installation and users guide before attempting to use, service or adjust the heater or pool filtering system.

Note: Turn off power to the unit prior to attempt service or repair.

<i>Problem</i>	<i>Cause</i>	<i>Solution</i>
Heat pump not running		
	1. No electricity	1. Switch on the electrical power
	2. Heat pump not turned on	2. Switch on the heat pump
	3. Water pump not running	3. Switch on the water pump
	4. Wrong temperature setting	4. Adjust the temperature setting
	5. Bypass wrong adjusted	5. Adjust bypass as shown in manual
	6. No gas pressure	6. Call your technician
	7. Time delayed operation	7. Wait 3 min for heat pump to start
	8. Air temperature below 10°C	8. Wait until temperature has risen
No sufficient heating		
	1. Obstacles blocking air flow	1. Increase access of fresh air
	2. Ice on the evaporator	2. Turn heat pump off (too cold air)
	3. By-pass wrong adjusted	3. Re-adjust the by-pass
	4. To much water flow	4. Adjust the by-pass

5.3 Check list at installation

ATTENTION / OPGELET / ATTENTION / ACHTUNG

1. Free area / vrije ruimte / espace libre / freier platz

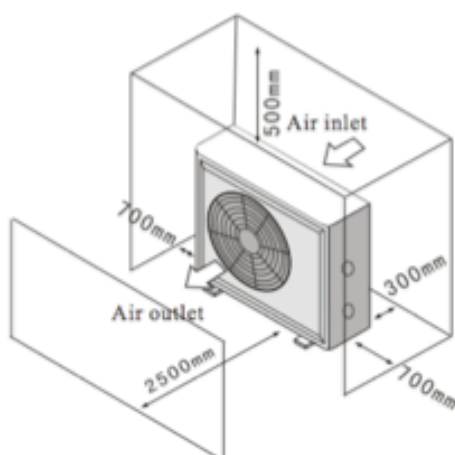

2. Install a by-pass / installeer een by-pass / installez un by-pass / installieren sie eine Überbrückung

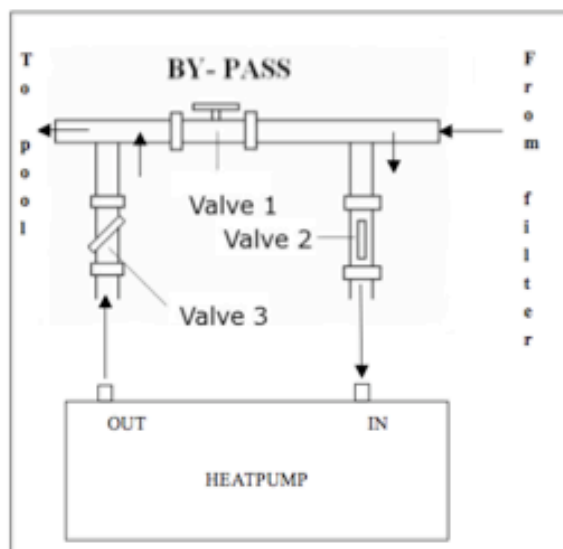

3. Electrical connection / elektrische aansluiting / raccordement électrique / elektrischer Anschluss

ECO-3	220-240V	6A	2*2,5 + 2,5mm ²
ECO-5	220-240V	10A	2*2,5 + 2,5 mm ²
ECO-8	220-240V	10A	2*2,5 + 2,5 mm ²
ECO-10	220-240V	16A	2*4 + 4 mm ²

Read the installation manual for more detailed instructions

Lees aandachtig de instructies in de installatiehandleiding

Lisez les instructions dans le manuel d'installation

Lesen sie die Anweisungen im Installation Handbuch

6. Detailed specifications

6.1 Electrical wiring diagram of the heat pump

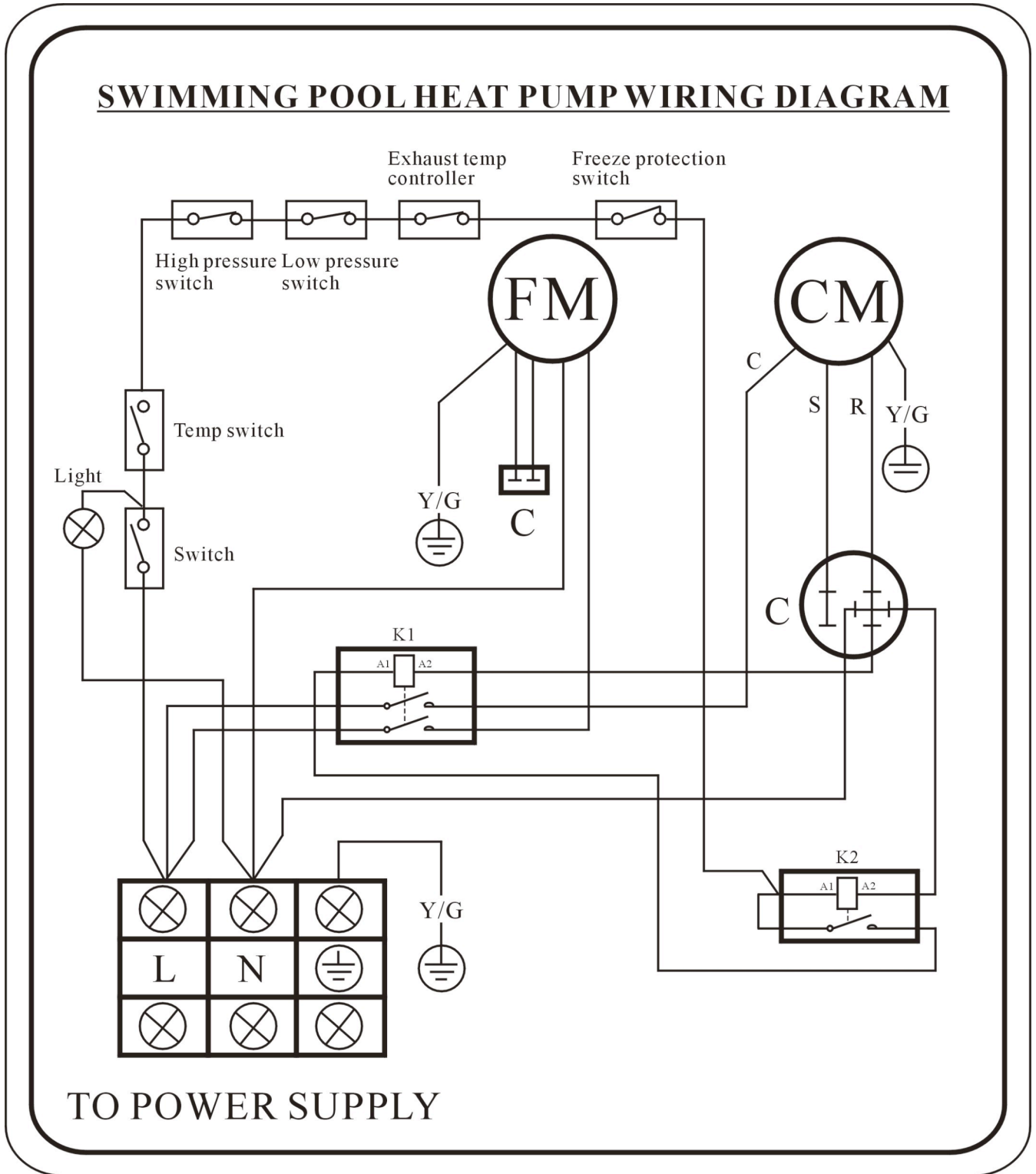

7. Warranty and return

7.1 Warranty

LIMITED WARRANTY

Thank you for purchasing our heat pump.

We warrant all parts to be free from manufacturing defects in materials and workmanship for a period of two years from the date of retail purchase.

This warranty is limited to the first retail purchaser, is not transferable, and does not apply to products that have been moved from their original installation sites. The liability of Lamberts Pool Products shall not exceed the repair or replacement of defective parts and does not include any costs for labor to remove and reinstall the defective part, transportation to or from the factory, and any other materials required to make the repair. This warranty does not cover failures or malfunctions resulting from the following:

1. Failure to properly install, operate or maintain the product in accordance with our published "Installation & Instruction Manual" provided with the product.
2. The workmanship of any installer of the product.
3. Not maintaining a proper chemical balance in your pool [pH level between 7,0 and 7,4. Total Alkalinity (TA) between 80 to 120 ppm. Free Chlorine between 0,5 – 1,2mg/l. Total Dissolved Solids (TDS) less than 1200 ppm. Salt maximum 3g/l]
4. Abuse, alteration, accident, fire, flood, lightning, rodents, insects, negligence or acts of Gods.
5. Scaling, freezing or other conditions causing inadequate water circulation.
6. Operating the product at water flow rates outside the published minimum and maximum specifications.
7. Use of non-factory authorized parts or accessories in conjunction with the product.
8. Chemical contamination of combustion air or improper use of sanitizing chemicals, such as introducing sanitizing chemicals upstream of the heater and cleaner hose or through the skimmer.
9. Overheating, incorrect wire runs, improper electrical supply, collateral damage caused by failure of O-rings, DE grids or cartridge elements, or damage caused by running the pump with insufficient quantities of water.

LIMITATION OF LIABILITY

This is the only warranty given by Manufacturer. No one is authorized to make any other warranties on our behalf.

THIS WARRANTY IS IN LIEU OF ALL OTHER WARRANTIES, EXPRESSED OR IMPLIED, INCLUDING BUT NOT LIMITED TO ANY IMPLIED WARRANTY OF FITNESS FOR A PARTICULAR PURPOSE AND MERCHANTABILITY. WE EXPRESSLY DISCLAIM AND EXCLUDE ANY LIABILITY FOR CONSEQUENTIAL, INCIDENTAL, INDIRECT OR PUNITIVE DAMAGES FOR BREACH OF ANY EXPRESSED OR IMPLIED WARRANTY.

This warranty gives you specific legal rights, which may vary, by country.

WARRANTY CLAIMS

For prompt warranty consideration, contact your dealer and provide the following information: proof of purchase, model number, serial number and date of installation. The installer will contact the factory for instructions regarding the claim and to determine the location of the nearest service center.

All returned parts must have a **Returned Material Authorization number** to be evaluated under the terms of this warranty.

For further information, please contact your local agent.

7.2 RMA request form



Propulsion Systems bvba
 Romeinse Baan 56
 B-1785 Brussegem - Belgium
 +32-2461 0253 Tel
 +32-2706 5960 Fax
 www.lambertspoolproducts.com

Company:				Date:	
Address:					
City:		Zip:		Country:	
Contact:				Phone:	
	E-mail:			Fax:	

Propulsion Systems contact name:		Date:	
----------------------------------	--	-------	--

Internal use			
RMA #:			
	Issued by:		Date:

Return for:

Copy of customer's invoice attached?

Other documents attached to RMA request? <input type="checkbox"/>
Description of documents:

Model no.:		Invoice no.:	
Serial no.:		Invoice date:	
Problem:			

Propulsion Systems warranty repair policy:

- Returns must be shipped freight prepaid. All return shipping charges are your responsibility.
- Propulsion Systems requires pre-authorization for the return of all products. Products not authorized for return shall be sent back to you at your expense.
- Propulsion Systems will repair or replace the products and will ship all products free via a carrier of our choice.
- We will ship, at your expense, via any express carrier service you request.

Return procedure:

- Before calling for an RMA number, please make sure that you have correctly followed the installation instructions and operating procedures located in the user's guide.
- Call our Return Merchandise Authorization department and request an RMA request Form.
- On the RMA Request Form, make sure you have filled in ALL the information fields.
- For returns within the warranty period, you must add a copy of your original sales invoice to your customer.
- Send RMA Request Form, sales invoice and other documents (pictures, ...) to fax +32-2-706.59.60 or e-mail johan@propulsionsystems.be. RMA number will be issued within 24 hours after proper documents have been received. Propulsion Systems may refuse to issue an RMA number in the event of failure to provide the above information mentioned in item (3) and (4).
- RMA number should be clearly written on the shipping label and the label placed on the shipping box.**
- All unlabeled, mismarked or illegibly marked products will be refused and returned, freight collect.
- All packages, which appear to be damaged at the time of delivery to Propulsion Systems will be refused "AS IS".
- Please be assured that the products sent to Propulsion Systems are the same products for which the number was issued. If the products do not match the products under the assigned RMA number, Propulsion Systems will return all products, freight collect.
- No return accepted without an RMA number, absolutely no exceptions.
- RMA number is only valid for 21 calendar days after authorization. We reserve the right to refuse returned item(s) beyond 21 days from the date RMA number is assigned.**

Out of warranty products:

Customers are responsible for the shipping and repair costs. The estimated repair costs will be given after the diagnosis of the returned products.
Diagnostic charge is 50,00€ and up.