

INSTRUCTION AND OPERATIONAL MANUAL

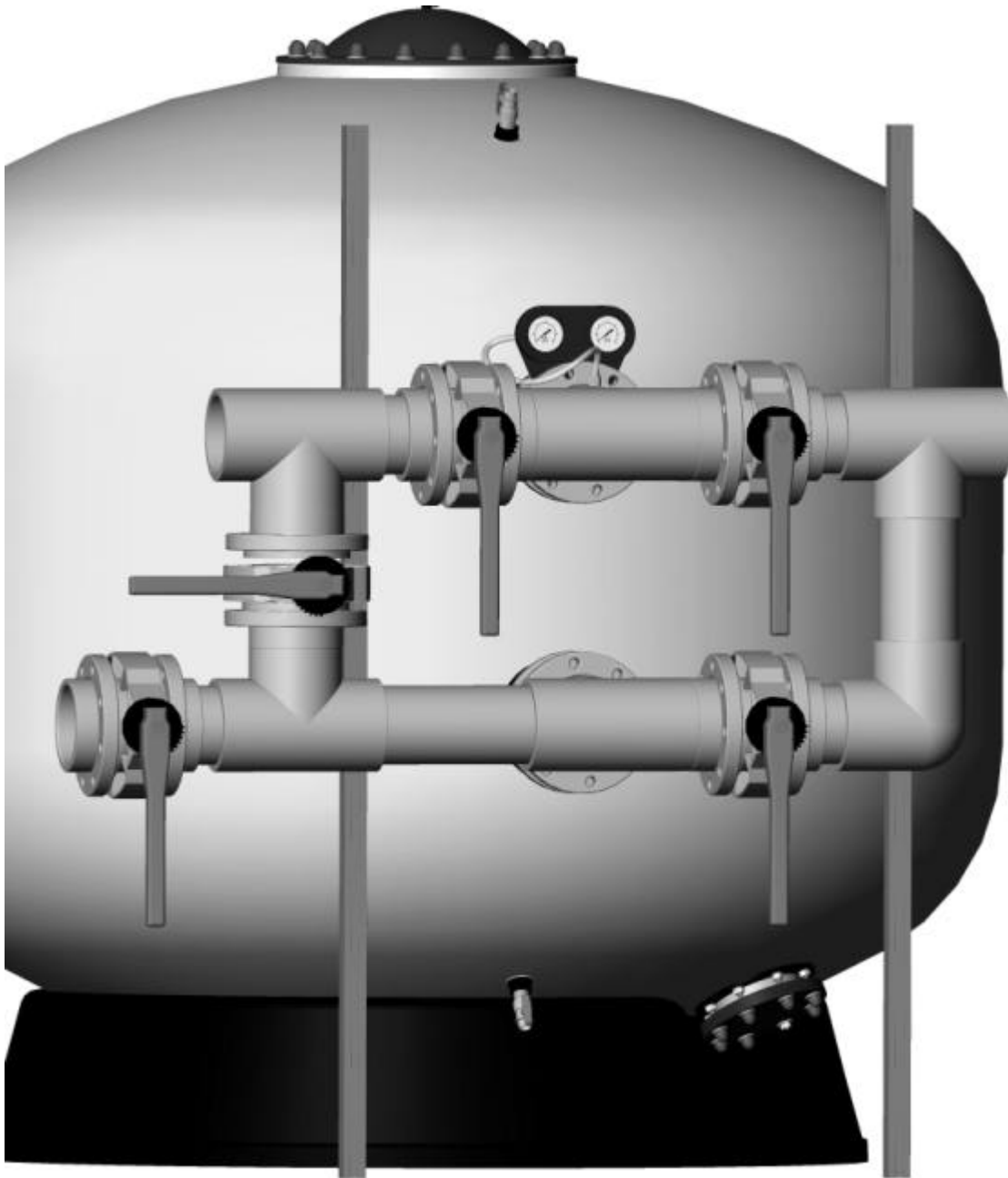

INDUSTRIAL POLYESTER FILTERS

1. Generalities	2
1.1. Filters.....	2
1.2. The filters	2
1.3. Choosing the filters and the type of installation	3
1.3.1. Characteristics of the filters	3
1.3.2. Characteristics of the installation	3
2. Installation	4
2.1. Installing the filters	4
2.2. Installing the battery supports	6
2.3. Installing the tube supports.....	6
3. Start-up	7
4. Normal operation cycle	8
4.1. Filtration.....	8
4.2. Wash	8
4.3. Rinse	8
4.4. Drainage.....	9
4.5. Closure	9
5. Valve battery. Their position in each operation	9
5.1. 4-valve batteries.....	9
5.2. 5-valve batteries.....	9
6. Draining the sand from the filter	10
7. Other recommendations of interest	10
8. Table of head loss from the filters	10
9. Maintaining the pool filters	10
9.1. Wintering the filter.....	11
10. Safety warnings	11
11. Solving problems or possible breakdowns	12

1. Generalities.

1.1.Pool filters.

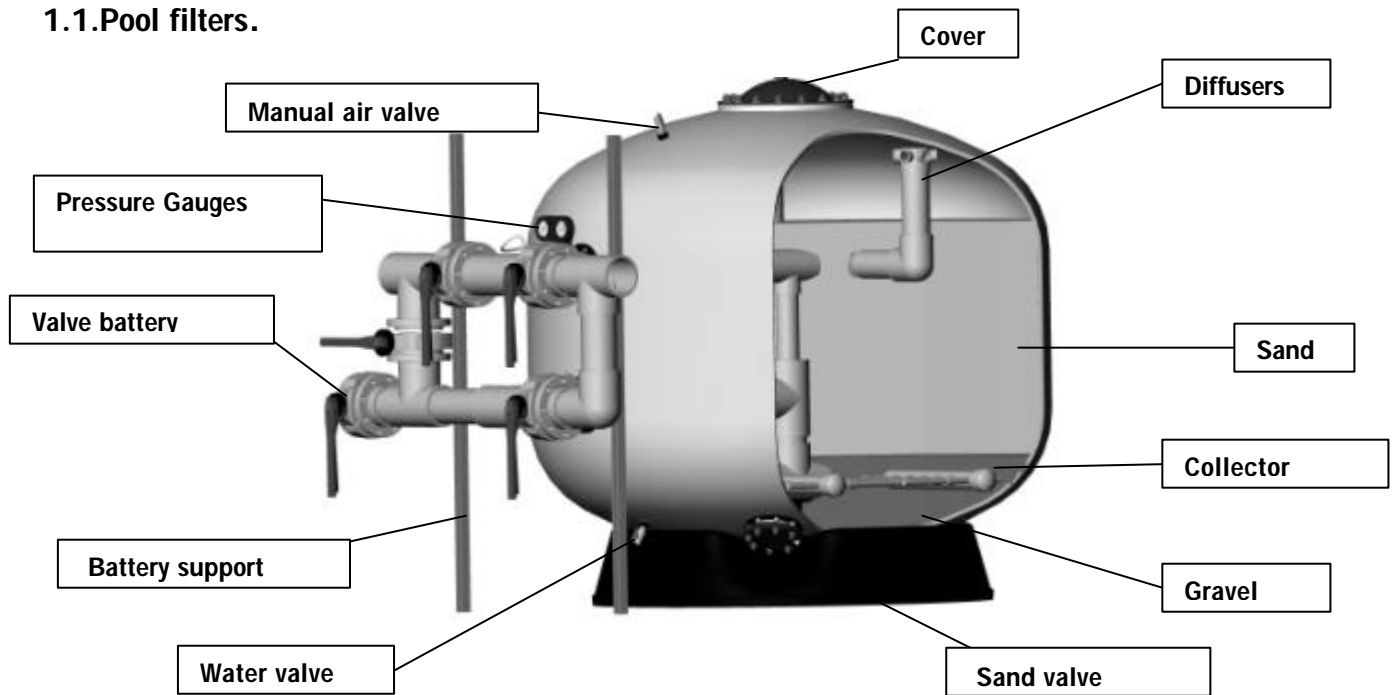

The filters are, without a doubt, the most important accessories for filtering water. And their object is to eliminate suspended materials and to clarify the water.

The effectiveness of proper filtration affects the results of the disinfectant treatment that any public pool is obligated to follow.

The physical principle of filtration consists in trapping the suspended particles found in the water as they pass through the filtration sand bed.

The water filtration and purification process includes a whole variety of elements, besides the filter, to take into account, like the pumps, chemical water treatments, pool structure accessories for ensuring the return and suction of the water, as well as other elements capable of ensuring proper circulation and maintaining water quality.

Normally, each country has its own private and public pool regulations, and the installers should consult them before carrying out any design or installment. For this reason, the elements and materials of the project should be designed and defined respecting the established standards.

Filtration quality depends on various parameters: the conception and form of the filter, the height of the filtration bed, the characteristics and grading of the filtration mass, etc. It should be noted that the filtration speed is a determining factor for obtaining good filtration quality.

Other important concepts to keep in mind when choosing a filter are the characteristics of the materials used in its manufacture, its working temperature and its working pressure.

1.2. The filters.

For manufacturing the filter deposit, totally anti-rust materials like polyester resins and fiberglass are used. The collector and diffuser, found inside it, are made of unalterable material, resistant to saltwater and designed to withstand a working pressure of 2.5 Kg./cm² and a maximum working temperature of 50°C. For greater pressure, consult the manufacturer.

Depending on the filtration speed, the filters are classified into three groups:

- SLOW FILTERS: Filtration speed from 10 to 20 m³/h/m².
- SEMI-RAPID FILTERS: Filtration speed from 20 to 40 m³/h/m².
- RAPID FILTERS: Filtration speed from 40 to 50 m³/h/m².

For proper filtration, we do not recommend exceeding 40 m³/h/m²., keeping in mind that the filtration quality depends directly upon the grading of the filtration sand and the height of the filtration bed.

1.3. Choosing the filters and the type of installation.

1.3.1. Characteristics of the filters.

For properly filtering pool water, we recommend that the maximum re-circulation time for the entire water volume of the pool be the following::

Public pools:	4 hours.
Semi-public pools:	6 hours.
Public pools for children:	1.5 hours.

On the other hand, another important parameter that directly affects filtration quality is the speed of the water passing through the filters. We recommend the following speeds:

Public pools:	20 m ³ /h/m ² .
Aquatic pools:	30 m ³ /h/m ² .
Semi-public pools:	40 m ³ /h/m ² .

Exceeding a speed of 40 m³/h/m² is never advisable.

However, you should consult current standards in each country.

Before installing the filters, you have to make sure that they comply with the above recommendations.

EXAMPLE: If we have a pool of 8m x 15m x 1.5m = 180m³, we require:

For public pools:	180m ³ /4 hours = 45m³/h (flow)
For semi-public pools:	180m ³ /6 hours = 30m³/h (flow)

So, we need a filter or a group of filters for a public pool that has a filtration capacity of **45 m³/h. a filtration speed of 20 m³/h/m².**

And for a semi-public pool, a filter or a group of filters that has a filtration capacity of **30m³/h. a filtration speed of 40m³/h/m²**

Whenever possible, for safety reasons in case of a breakdown, use a minimum of two filters working at the same time with a filtration capacity each of 50 % of the water volume to be filtered.

1.3.2. Characteristics of the installation.

For choosing the pump, you must take the necessary flow of 10 m.c.a. into account.

As for the number of pumps to be installed, we advise placing the same number of pumps as there are filters, each one with the flow necessary to obtain the desired filtration speed in a filter.

However, the return of each pump should flow into the general inlet tubing that is directed towards the filters. In this way, when the filters are filtering the pool water, all the pumps are operating. On the other hand, when you want to wash the filters, they are done alternately, meaning that with all the pumps operating, a determined number of filters will be closed (in order to obtain a wash speed from 40 to 50 m³/h/m²). Once the first group of filters is washed, these will close and then the second group will be washed.

With this set-up, we eliminate the need for having spare pumps for washing the filters.

Just like with the return, we recommend that the suction tubing of each pump comes from the general water suction tubing of the pool.

For obtaining good pool water quality, it is necessary to design the installation in such a way that the water to be filtered comes from both the surface and the bottom of the pool.

When calculating the return and suction tubing for the pool water, keep the following speeds in mind:

- Return line of filtered water to the pool: Maximum speed in the line: 2 m/sec.
- Suction line of water to be filtered: Maximum speed in the line: 1.5 m/sec.

2. Installation.

2.1. Installing the filters

NOTE: The filters are delivered conveniently packed and due to their weight, size and difficulties arising in placing them, we recommend that their handling and movement be done with mechanical apparatus (forklifts, cranes, etc.).

Ensuring that the filters do not receive bumps that could damage their polyester body or base is very important.

Sand should be loaded once the filter is installed into its exact location, following the instructions in the START-UP SECTION.

The steps to be taken for correctly installing the filters are the following:

- Install the filter(s) into its (their) exact location.
- Assemble the battery(s) or selector valve correctly onto the filter(s).
- Install the adequate battery supports and adjust them (height, etc.) correctly. (see section 2.2).
- Connect the battery or selector valve with the pump return tubing, the return tubing to the pool and the drainage tubing.

We recommend installing the filters below the water level of the pool and as close to the pool structure as possible.

We recommend that the housing, where the filters are installed, has ventilation and adequate drains so that, in case of an accident, the water can escape through any tube, filter, pump, etc. By being able to evacuate it, the risk of damaging existing installations (pumps, control panels, etc.) is avoided.

If for any reason, these drains are unavailable, an alternative automated system should be installed for evacuating water from the chamber.

The filters should be installed in such a way that the base lies completely stable upon a totally horizontal surface.

Once the installation is finished and before putting the sand inside the filter, you should start the system and check that all of the system's elements operate correctly.

In case it is necessary, the installation can be provided with wall supports for the tubing of every diameter up to 225mm. (see section 2.3).

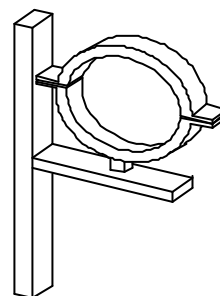

Given the fact that the filters require periodic inspections and in preparation for eventual interventions inside it, leaving a minimal amount of free space around and above the filter is essential.

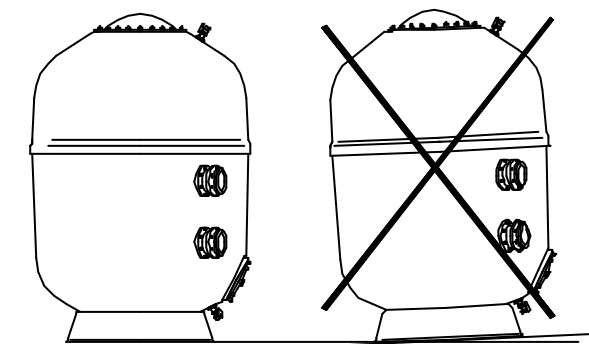
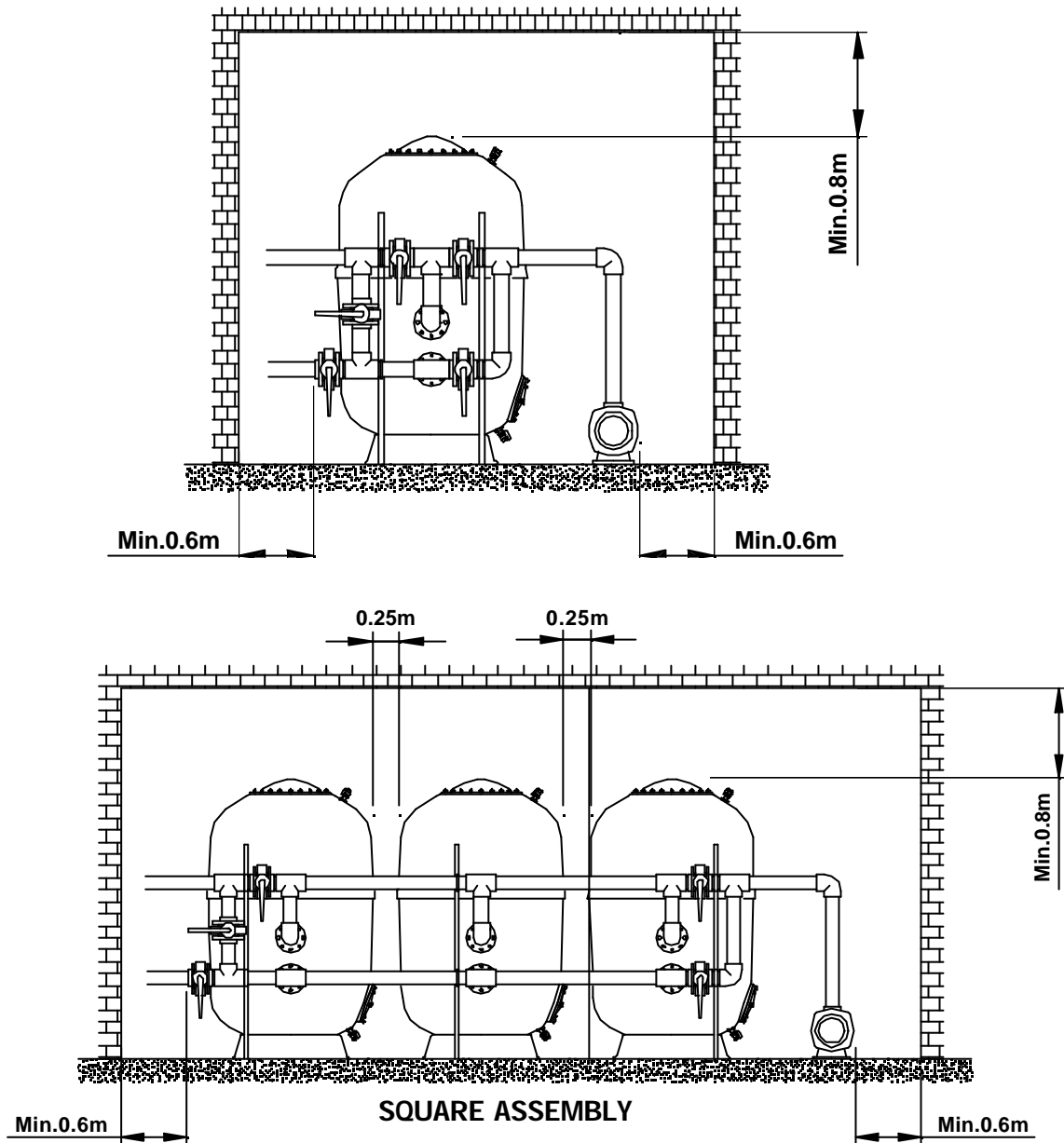

Set the filter on a totally horizontal surface

2.2 Installing battery supports.

Once the battery has been installed, it is a good idea to install special supports for supporting the weight of the battery and the water that circulates through it.

We recommend installing the following height-adjustable supports:

DESCRIPTION
ZINC-COATED STEEL TUBE (BARS)
Height of 1.85 m
Height of 2.30 m
Height of 3.00 m

ACCESSORY BOX:
2 anti-vibration brackets, anchor plug and accessories
For tube D 75
For tube D 90
For tube D 110
For tube D 125
For tube D 140
For tube D 160 - 4 valves
For tube D 200 - 4 valves
For tube D 225 - 4 valves
For tube D 160 - 5 valves
For tube D 200 - 5 valves
For tube D 225 - 5 valves

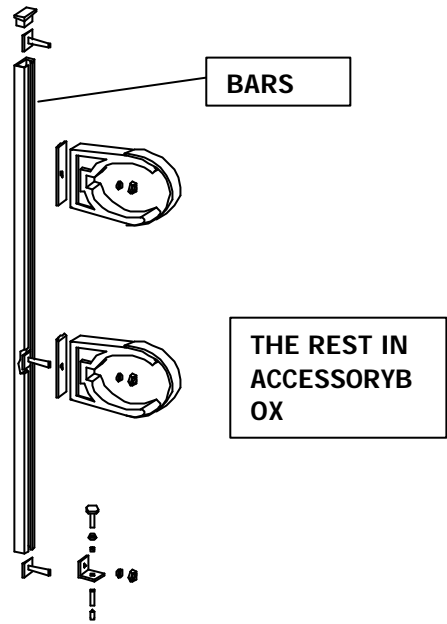

- When choosing the bar, check out the height of the chosen filter's connections.
- For the accessory box, check out the diameter of the batteries and the number of valves.
- For the battery of just one filter, two bars and two accessory boxes are necessary, for batteries of two or more filters, we recommend at least one bar and box per filter.

For installing, first, you have to adjust the height of the brackets in relation to the battery and then fasten the support on the floor with the corresponding anchor.

2.3 Installing the tubing supports.

When assembling the installation, you have to place supports on the tubing sections in order to avoid vibrations and buckling that could damage or break them. For this reason, we recommend installing the following supports:

D Tubing
75
90
110
125
140
160
200
225

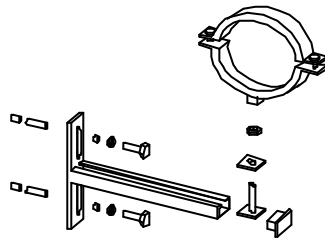

For installing them, follow the steps below:

- 1/ Take the bracket apart in two halves.
- 2/ Set the inner half of the bracket into the iron support.
- 3/ Mark the position of the support.
- 4/ Drill the holes into the wall.
- 5/ Fasten the support onto the wall.
- 6/ Fasten the tubing with the flange.

3. Start-up

After finishing the installment and before placing sand inside the filters, you should carry out a hydraulic check of both the filters and the installation in order to make sure that it is assembled properly. Next, the filters need to be filled with sand, keeping the size and quality in mind of what will be the filtration mass from now.

Attention: Before filling the filter, in case the sand drain cover has been removed, replace it and make sure the joint located on the cover and the housing in the ring stay clean. You should also grease the screws before putting the nuts on.

ATTENTION: Do not clean the plastic components with chemical products, acetone etc.

For correctly filling the filters with sand, we recommend:

1. Removing the filter cover, trying not to damaging the joint and the cover lock.
2. Making sure all the filter components (collector arms, etc.) are in good shape, since they could have suffered some damage during transport.
3. Filling the filter about halfway with water.
4. Introducing the sand (silica), keeping in mind that gravel of at least 1 to 2 mm in size must be introduced first until covering the collector arms (approximately 10 cm). This should be done very carefully so as not to damage the inner filter components. As the filter is being filled with sand, take the precaution of distributing the sand over the entire filter surface.
5. Introducing sand from 0.4 to 0.8 mm in size up to the maximum limit of filtration height (the distance between the upper part of the filtration bed and the diffuser outlets should be at least 25% of the filtration bed height).
6. Closing the filter by placing the joint in the correct position and replacing the cover carefully without moving it from its position.
7. Before starting, after loading and conveniently closing the filter, washing the filter is necessary. In order to do so, follow the instructions in the filter wash section.

Attention: Clean the surface of the filter neck, the joint and the cover meticulously before assembling. You should also grease the screws before putting the nuts on and after the cover has been mounted, place the trim (supplied with the filter) onto the screws.

4. Normal operation cycle

4.1. Filtration.

WITH THE PUMP STOPPED, place the valves in the filter position indicated in the diagram.

During filter operation, we recommend periodically observing the pressure gauges of the inlets and outlets and washing the filter when the pressure difference is equal to or greater than 0.8 – 1 Kg/cm².

As for industrial uses, the pressure difference should not exceed 0.6-0.8 Kg/cm².

Normally, when filtering pools, the inlet pressure gauge indicates a pressure of 0.8-1 Kg/cm². and the outlet pressure gauge 0.4-0.8 Kg/cm². (standard pressures when the filter is clean). As the filtration bed gets dirty through use, the inlet pressure gauge will experience an increase in pressure while the outlet pressure gauge will suffer a drop in its working pressure.

ATTENTION. NEVER EXCEED THE FILTER'S MAXIMUM PRESSURE.

4.2. Wash.

The sand load (filtration bed) forms thousands of water canals, which logically collect the impurities and solid residues that comes from filtering water. With time, these residues block the water canals, so that periodically cleaning the filter in order to leave it in optimal working conditions and pouring the dirt found in the filtration bed through the drain is necessary.

According to DIN 19643, washing time has to be 7 minutes at a speed of about 50 m³/h/m².

We advise placing a sighting-tube in the drainage tubing in order to observe the dirtiness of the water coming from the filter when cleaning and to determine the length of the washing time.

We do not recommend surpassing 50 m³/h/m² in order to avoid some of the sand from being expelled through the drain.

For performing the wash operation and ALWAYS WITH THE PUMP STOPPED, place the valves in the wash position indicated in the diagram.

4.3. Rinse.

This operation is recommended after the WASH. Its objective is expelling the remains of residues that could have penetrated the collectors during the wash cycle of the filter.

This operation should be performed for 3 minutes (according to DIN 19643) and will prevent muddy water from circulating into the pool.

For performing this operation, place the valves into the rinse position indicated in the diagram, ALWAYS WITH THE PUMP STOPPED, and immediately after, place them to the filter position.

The rinse operation can only be performed if the battery has 5 valves or if we have a selector valve in the filter.

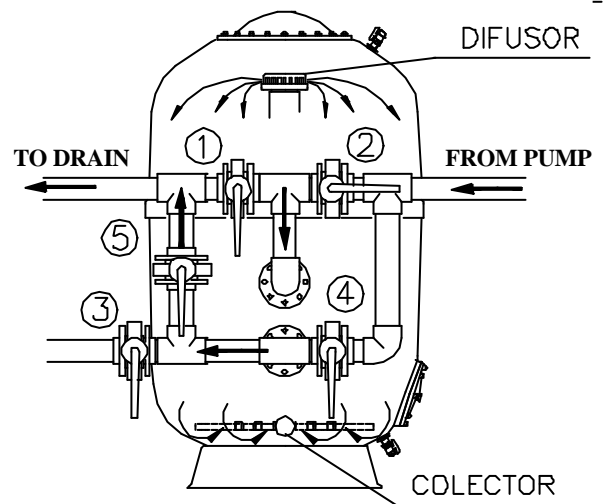
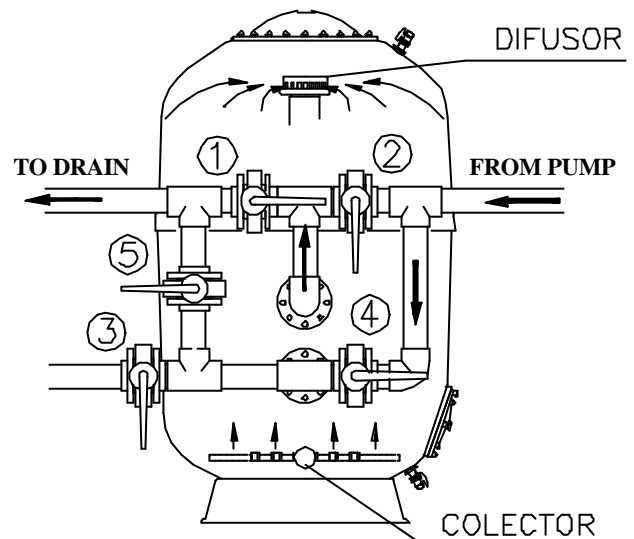
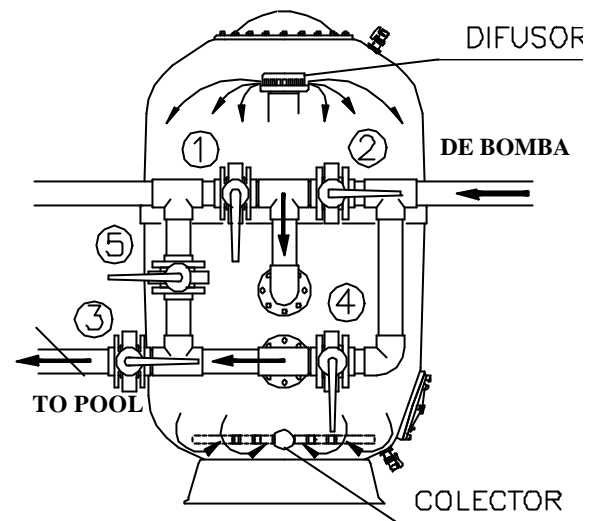

4.4. Drainage.

Empty the pool when necessary and in case the pool does not have a drain on the bottom directly connected to the sewer system, drainage can be carried out by using the filter pump. Place the valves in drainage position indicated in the diagram.

For this end and before connecting the drainage, the skimmer valves, the overflow canal and the bottom cleaner must be closed.

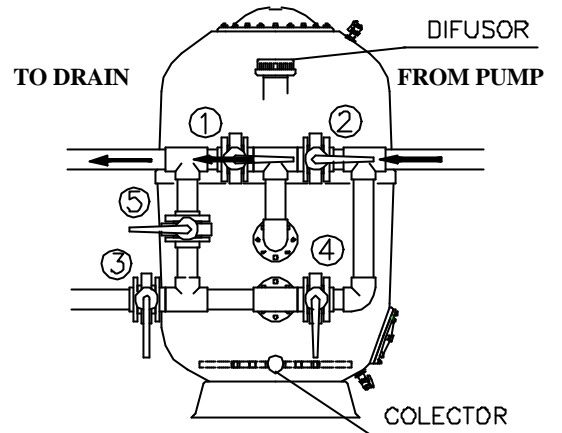

4.5. Closure.

As its name indicates, all the battery valves are closed.

This operation is used for maintaining the filter, cleaning the pre-filter, etc.

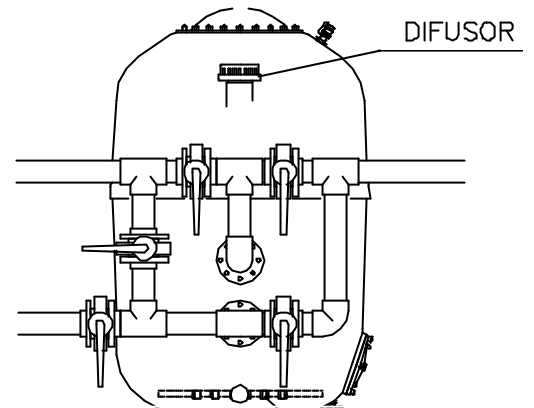

5. Valve battery. Their position in each operation.

5.1. 4-valve batteries.

Control diagram for 4-valve batteries.

Position	1	2	3	4
Filtration	Closed	Open	Open	Closed
Wash	Open	Closed	Closed	Open
Drainage	Open	Open	Closed	Closed
Closure	Closed	Closed	Closed	Closed

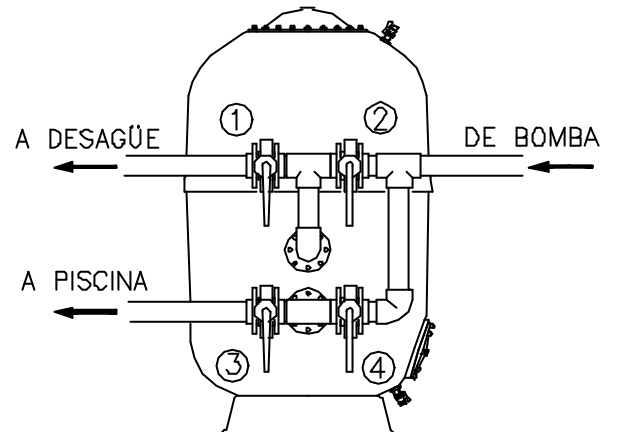

5.2. 5-valve batteries.

Control diagram for 4-valve batteries.

Position	1	2	3	4	5
Filtration	Closed	Open	Open	Closed	Closed
Wash	Open	Closed	Closed	Open	Closed
Rinse	Closed	Open	Closed	Closed	Open
Drainage	Open	Open	Closed	Closed	Closed
Closure	Closed	Closed	Closed	Closed	Closed

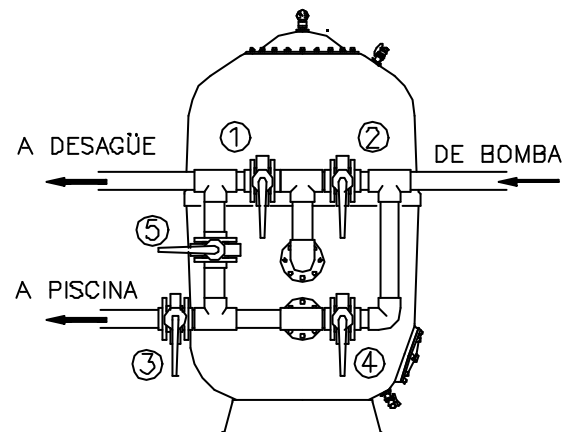

6. Draining the sand from the filter.

For emptying sand from the filter, proceed in the following way:

1. Drain the water from the filter.
2. Remove the cover.
3. As the sand is draining, remove it from the valve in order to prevent blockage.
4. It will be necessary for someone to enter the filter through the upper mouth in order to bring the sand closer to the valve for facilitating its exit.
5. For refilling the filter with sand, follow the START-UP instructions.

7. Other recommendations of interest.

- In the interior assembly, the number of collectors and diffusers vary according to the size and type of the filter. The function of the diffuser(s) is distributing the water as uniformly as possible over the filtration bed. The function of the collectors is collecting the previously filtered water and directing it towards the filter outlet.
- Each filter is equipped with a manual air valve installed in the upper part of the filter. Likewise, all the filters have a manual water valve installed in the lower part that can be connected directly to the sewer system.
- Once the pool installation is finished, we recommend cleaning the filter well with pressurized water in order to clean out all the dust and dirt coming from the installation or construction work. Remember that the system can be totally automated, in which case, a technician will recommend the most adequate system for your needs.
- In case the installation is stopped during a long period of time, we advise emptying the water from the filter.

8. Table of head loss from the filters, with sand.

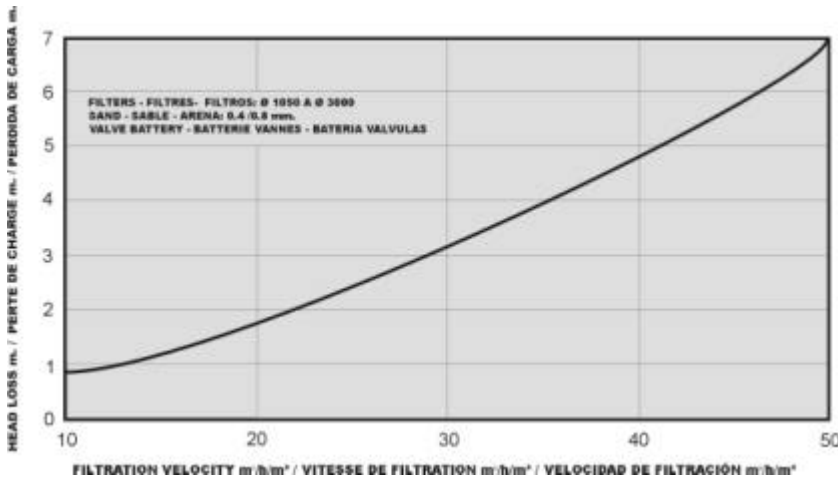

9. Maintaining the pool filters.

Always having the filters in the proper conditions is important, since the good quality of the water depends on it.

- Once a year, we recommend substituting the sand, in order to eliminate algae, sun-tanning oil and calcium or magnesium deposits that accumulate inside it.
- Having all the components in the proper conditions is important. For this end, they should be checked regularly, and deteriorated joints and pieces should be substituted when necessary.
- For cleaning the filter, do not use solvents, since they can damage components made with plastic material. The filter can be cleaned easily with water and soap.

9.1 Conservation du filtre pendant l'hiver

Pour ne pas endommager les composants du filtre pendant l'hiver, procéder comme suit :

- Le laver et le rincer conformément aux instructions.
- Arrêter la pompe.
- Vider l'eau du filtre.
- Fermer les valves des conduites d'aspiration et d'impulsion pour isoler le filtre.
- Ouvrir le couvercle du filtre pour l'aérer pendant la période de non-fonctionnement.
- Nous conseillons de vider également toutes les conduites pour éviter leur rupture en cas de gel.

10. Mises en gardes de sécurité

- Ne faites pas fonctionner l'appareil sans eau.
- Avant de manipuler le filtre ou les valves, assurez-vous que la pompe est bien à l'arrêt et que le filtre n'est soumis à aucune pression. Pour plus de sécurité, débrancher la pompe et les éventuelles installations électriques.
- Ne jamais brancher directement le filtre à l'eau courante, car la pression de l'eau peut être très forte et dépasser la pression maximale de travail du filtre.
- Purger l'air de l'intérieur du filtre avant de lancer le cycle.
- Les unions étant maintenues par des joints, ne serrez pas excessivement les écrous.
- Ne pas nettoyer les pièces en plastique avec des produits dissolvants car ces derniers pourraient leur faire perdre leurs propriétés.
- Empêchez les enfants de manipuler les filtres ou de jouer à proximité.
- Protéger les filtres contre le gel.
- N'installez pas votre filtre à proximité d'installations électriques n'étant pas conformes aux normes en vigueur.
- Avant de mettre la pompe en marche, vérifiez que le couvercle du filtre est bien refermé.
- Installer le filtre dans un endroit bien ventilé et équipé des évacuations d'eau nécessaires, et si possible sous le niveau d'eau de la piscine afin d'éviter une dépression en son intérieur.

11. Résolution de problèmes ou de pannes éventuelles

PROBLÈME	CAUSE	SOLUTION
Débit de filtrage faible.	Pré-filtre de la pompe sale.	Nettoyer le pré-filtre.
	Le moteur de la pompe tourne à l'envers	Inverser le sens de rotation du moteur de la pompe.
	Filtre sale.	Procéder à un « lavage ».
	Conduites bouchées.	Procéder à son nettoyage.
	De l'air entre dans la pompe.	Vérifier toute l'installation et solutionner les fuites éventuelles.
Le manomètre oscille violemment.	De l'air entre dans la pompe.	Solutionner les fuites d'eau au niveau du pré-filtre et des conduites d'aspiration.
	L'aspiration est semi-fermée.	Vérifier si les valves d'aspiration sont bien ouvertes.
De l'air entre dans la pompe.	Présence d'algues dans la piscine.	Procéder à un traitement chimique.
	Filtre sale.	Procéder à un « lavage ».
	Le pH de l'eau est élevé (eau trouble)	Faire diminuer le pH.
	Manque de chlore (eau verdâtre)	Ajouter du chlore.
Augmentation rapide de pression, bulles au niveau des bouches d'arrivée.	Niveau insuffisant de l'eau de la piscine.	Remplir la piscine.
	Valves d'aspiration partiellement fermées.	Vérifier et ouvrir les valves.
	Pré-filtre de la pompe sale.	Nettoyer le pré-filtre.

WE RESERVE THE RIGHT TO TOTALLY OR PARTIALLY CHANGE THE CHARACTERISTICS OF OUR ARTICLES OR THE CONTENTS OF THIS DOCUMENT WITHOUT PRIOR NOTICE.